

**THE GNSS REPEATER TECHNOLOGY EXPERT**



**ROGER™ GNSS-L1G1GA-EU/-UK/-US**

**Repeater**

**User Manual**

**Time2Act™**

*Thank you for choosing Roger™-GPS Ltd for your requirements. We appreciate your support and are certain that our product will serve you reliably. This product is designed to provide many years of reliable service, provided it is used as intended and taken care of. This user manual will assist you in assembly and general operation of this product.*

*It is not our intent to teach you about GNSS satellite navigation. It is assumed that you are an experienced user of satellite navigation products and services with the relevant skills and experience necessary to use this product safely. If after reading the following instructions, you are unsure or uncomfortable about safely using this product, we urge you to seek additional information through our local partner or widely available GNSS and GPS information sources. Some of the information sources are listed at the end of this manual.*

### **IMPORTANT!**

Read carefully the contents of this manual before assembly or operation of this product.

**Please check, apply and fulfil the radio licensing regulations and directives of the use of GNSS repeaters in your country from your regulator.**

### **ROGER™ GNSS Repeater key features**

1. ROGER™ GNSS Repeater products are designed and manufactured in Finland.
2. ROGER™ GNSS Repeater products are carefully tested and have full two years warranty.
3. ROGER™ GNSS Repeater products are CE-certified and approved worldwide by the communications authorities e.g. in EEA countries for use as radio-licensed devices.
4. ROGER™ GNSS repeaters have a proprietary gain control system that provides up to 15dB more signal than other systems in the market and providing up to 10 times more signal gain while still maintaining the ETSI EN 302 645 standard.
5. ROGER™ GNSS intelligent repeaters provide more gain in difficult conditions and oscillation (feedback) protection to protect your GNSS signals.
6. SUMMARY
  - Automatic gain limitation
  - Oscillation prevention with indicator
  - Maximal coverage for CE approved repeater
  - Seamless GNSS service and signal when moving indoors to outdoors
  - Full product family with repeaters, amplifiers, splitters and power supplies



### **Roger-GPS Ltd. – the Company**

The increasing dependence on GNSS – Global Navigation Satellite System (GPS, Glonass, Galileo, Beidou) and their applications has placed an additional demand on them having the capability of operating both indoors and outdoors without interruption to the data.

ROGER™GPS Ltd. is a company that specializes in GNSS (GPS) repeating technology. The ROGER™-GPS proven system concept enables the use of GNSS repeater devices to provide services in places where it was previously unavailable. We have a wide range of customers who always require reliable GNSS signal reception or time synchronization; they include telecommunications providers, Public Safety Services, Utilities, Defence, Transport, Airlines, Logistics and the companies who manufacture, sell and maintain GNSS systems, receivers, terminals and services.

The Roger™-GPS Ltd. business concept permits the use of GNSS repeater devices and services in places where it was not previously possible.

In September 2008 Sparklike Ltd. launched the first CE-certified GPS repeater product family approved by the communications authorities in Finland and Sweden for use as radio-licensed device. ROGER™-GPS was established as spin-off in February 2009 to continue the development, manufacturing and marketing of GPS products started by Sparklike Ltd.

The private company owners of Roger-GPS Ltd. are Maktub Consulting Ltd., and Naxim Ltd.

#### **CE CERTIFICATE, radio licensing**

The Roger™-GPS L1 GPS repeater product was recertified in January 2012 according to the renewed ETSI EN 302 645 V1.1.1 (2010-03) Harmonized European Standard. The equipment conforms to the essential requirements of Directive 2014/53/EU (hereafter “The Radio Equipment Directive”) and EN 301 489-1 (V1.8.1), EN 301 489-3 (V1.4.1), EN 302 645 (V1.1.1).

Roger™-GPS products have been classified in NATO N-S-N code and NATO NCAGE code.

***This product can be put into service throughout the European Economic Area. Study this documentation of use and installation instruction provided in this manual and in your local country sales area of Roger™-GPS LTD. The user must have the necessary frequency licence for operation in that area.***



## DECLARATION OF CONFORMITY

We

*Roger™-GPS Ltd.*  
*Finnoonnaitynkujä 4*  
*FI-02270 Espoo, Finland*  
*Email: [roger@gps-repeating.com](mailto:roger@gps-repeating.com)*  
*[www.gps-repeating.com](http://www.gps-repeating.com)*

Declare under our own responsibility that the products

**GPSR-1, GPSR-L2, GNSS-L1G1GA, GNSS-L1G1GA-IP67, GNSS-L1L2-67D1,  
GNSS-L1L2G1GA-67, GNSS-L1G1GA-CHAIN, GNSS-L1G1GA-CHAIN-Y**

Commercial name: ROGER™ - GPS or ROGER™ - GNSS Repeater.

Which are manufactured in Finland and to which this declaration refers conforms with the relevant standards or other standardising documents:

- **EMC:** EN 302 645 (V1.1.1), EN 301 489-1 (V1.8.1), EN 301 489-3 (V1.4.1)
- **RF:** EN 302 645 (V1.1.1)
- Intertek ETL Semko Oy (FINAS T199) product compliance test reports 200630A-EMC and 200630C-RF.

According to regulations in Radio Equipment Directive 2014/53/EU.

The product carries the CE mark:



*This declaration of conformity is valid from 01st of December 2017*

**Authorised Signatory:**

A handwritten signature in blue ink, appearing to be "S. Ruoko", written over a horizontal line.

Simo Ruoko, CEO, Roger™-GPS Oy (Ltd.)

## What is ROGER™ GNSS Repeater?

The ROGER™ GNSS repeater operates by receiving GNSS satellite signals with an externally mounted antenna and relaying or repeating those signals to the area requiring coverage.

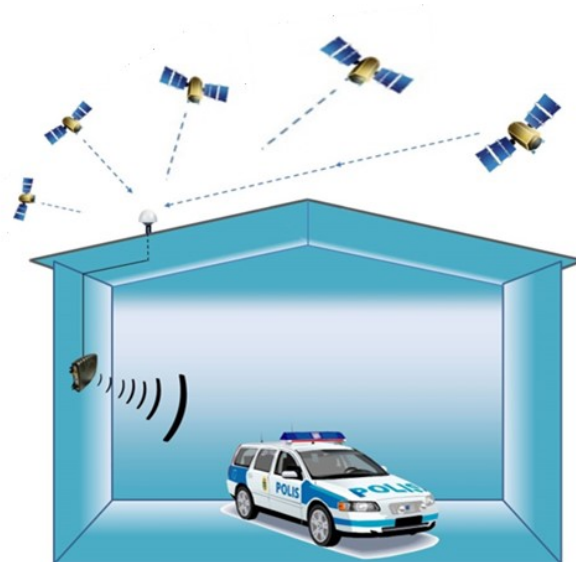

To use GNSS satellite devices inside your building you will need a repeater system to relay the signals from the outside to inside where there is no coverage. A repeater is a device that receives GNSS signals and re-transmits them to the area required. This is achieved by connecting the repeater to an externally mounted antenna via a coaxial cable to its location inside the building.

The GNSS satellite navigation device can now receive the GNSS signal using the relayed signal from the ROGER™ GNSS repeater. When the satellite navigation device is moved from the repeater covered area to outdoors, the receiver seamlessly tracks the location, without resorting to the time-consuming acquisition of GNSS almanac data (its history).

### Notes:

1. The ROGER™ GNSS repeater can be used for indoor navigation, however it should be noted that the receiver gives the position of the outdoor antenna.
2. The ROGER™ GNSS repeater fulfils the EN 302 645 V1.1.1 (2010-03) specification requirements, meaning that it can be used throughout the EEA and in fact, world-wide.
3. The use (taking into use) of GNSS repeaters (such as ROGER™ GNSS Repeaters) in many markets requires a radio licence to allow its use. The GNSS repeaters are intended for use by professional business users, companies and institutes. Check the licensing regulations, conditions and how to apply for a license from your local regulator authority before operation.
4. If the user of the GNSS repeater is an individual person, a radio license must be applied for before the GNSS repeater is taken into use, usually available from the local regulation authority.

### Description of GNSS Repeater controls and connectors (applies to repeater GNSS-L1G1GA):

1. Gain control knob: The gain control knob is used to control the output signal level (gain variation when turning the knob is 0-40dB) of the GNSS repeater output power.
2. DC power connector: The repeater power is supplied through the DC input connector. The connection is reverse polarity protected with 12V ⚡
3. Receiving antenna connector: The outdoor antenna front panel with the coaxial cable.
  - a. ROGER™-GPS has product packages that include
  - b. Alternatively, a 50Ω custom cable can be used on the front panel, the connector is SMA female so the cable should terminate with a SMA male. The other end of the cable should terminate in a TNC male, the other end of the cable should terminate in a TNC female, the other end of the cable should terminate in a TNC female, the other end of the cable should terminate in a TNC female.
  - c. The repeater feeds +5VDC 100mA for active outdoor antenna.
4. Status LED indicator
5. Integrated transmitter (TX) antenna inside the case



### ROGER™-GPS Repeater GNSS-L1G1GA

A single ROGER™ GNSS Repeater is enough to provide a GNSS indoor coverage area up to 1600 square meters (m<sup>2</sup>). The modern receivers can detect the signal at very low power levels, so the distance can reach up to 50-60 meters from the repeater's center, depending on surrounding structures. Several ROGER™ GNSS Repeaters can be installed in the same building. Alternatively, the signal coverage provided by a single package can be extended with ROGER™ GNSS additional products such as line amplifiers and signal splitters.

### WHAT IS GNSS-L1G1GA (-EU/-UK/-US) PRODUCT

- 1x ROGER™ GNSS Repeater unit GNSS-L1G1GA
- 1x Power supply with EU or UK or US plug respectively
- 1x User Manual in English

## ROGER™ GNSS repeater installation for GNSS-L1G1GA

Prior to commencing work on the installation, make a survey of the locations of the individual units, ensuring that:

1. The antenna has good line of sight to the sky and is not shrouded or shadowed by buildings, trees etc. and will not cause an obstruction to doors, windows, or ventilators and is located away from any machinery HVAC, fans etc. **Always connect the antenna cable before powering the repeater.**
2. The antenna feeder cable can easily be routed indoors and can be properly secured to walls and or ceilings.
3. The building protection and integrity is not compromised; i.e. breaching of fire stopped compartments.
4. If possible, install the power supply and antenna feeder cables away from existing cables, pipes etc.
5. There is a nearby power supply to connect the repeater to.
6. The final location of the repeater allows for maximum coverage of the area.

Install the GNSS repeater transmitter by fixing it to the ceiling, wall or other suitable mounting point. The repeater has an integrated transmitter TX antenna, located internally, on the same side as the status LED. The transmitter antenna generally radiates in the same direction as the LED. Ideally the transmitter should be located so that any desired GNSS receiving location, for example an antenna on top of a van in a garage has a direct line-of-sight to the repeater antenna. **After installation, prior to switching on, ensure all connections are tight.**

Switch the power on and the indicator LED will flash green for between two and three seconds during the start-up phase.

Turn the control knob in order to set the gain. A higher gain increases the coverage of the GNSS signal. Watch for the LED flashing to red and green, this means the maximum power has been reached.

Turning the knob too far clockwise will result in the LED turning red, indicating the gain setting is too high.

Constant green light indicates proper gain setting. Turning the knob too far counterclockwise will result in the green LED to blink indicating too low gain setting.



**The indications of the status LEDs are:****CONSTANT GREEN:**

The transmitter is working correctly, no further adjustment is required.

**CONSTANT RED/GREEN:**

The transmitter is working at its maximum output and the gain should be reduced slightly until a constant green is achieved.

**CONSTANT RED:**

The Transmitter has detected an error or interfering signal. One reason may be that the external antenna is picking up the signal from the transmitter and a feedback oscillation is occurring; it is strongly advised not to locate the external antenna and repeater too close together.

It may be that the power is set too high; decrease the gain on the repeater slightly.

Another common reason is that there is an interference source close to the receiving antenna. Locating the antenna, repeater and associated cables as far away from existing wiring, machinery and pipework will normally avoid this situation.

**Troubleshooting guide:**

Problem: No LED indication

Solution: Check power supply and connection.

Problem: Red light is on.

Solution: The gain setting is too high. Turn the control knob counterclockwise to decrease the gain until the green LED is lit.

Problem: Green light flashing around 5 times per second, red light is off.

Solution: Transmitted signal level is too low. Turn the control knob clockwise to increase the gain. In normal operation, only the green LED is continually on. In all other cases please check the antenna connections at both ends before making any gain adjustments.



### Extending the ROGER™ repeater’s distance from the outdoor antenna.

#### ROGER™ GNSS Amplifier (GNSS-A)

ROGER™ GNSS Line Amplifier is used to allow longer cable runs and/or signal splitting to several GNSS Repeaters.

It has a gain of +16dB and it includes a filter to remove unwanted signals that may have entered the cable at some point. Amplifier is powered through the output signal cable by the ROGER™ GNSS Repeater and it passes on DC power for the GNSS receiving antenna or another GNSS line amplifier.

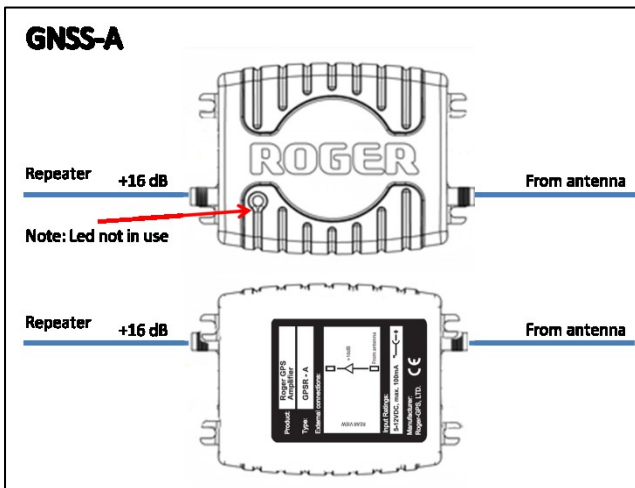

### Extending the number of repeaters by adding a Splitter 1 to 5.

#### ROGER™ GNSS Splitter 1 to 5 (GNSS-S)

With the ROGER™ GNSS Signal Splitter, the signal from one external antenna can be redistributed to up to five repeater units.

It is advisable to use a separate amplifier with the signal splitter to ensure adequate transmission power to all the five repeaters. If the signal is to be transmitted to fewer than five repeaters, the unused ports must be terminated with a 50ohm termination. The splitter is powered through the output signal cable by the ROGER™ GNSS Repeater and it passes on DC power for the GNSS receiving antenna or GNSS line amplifier.

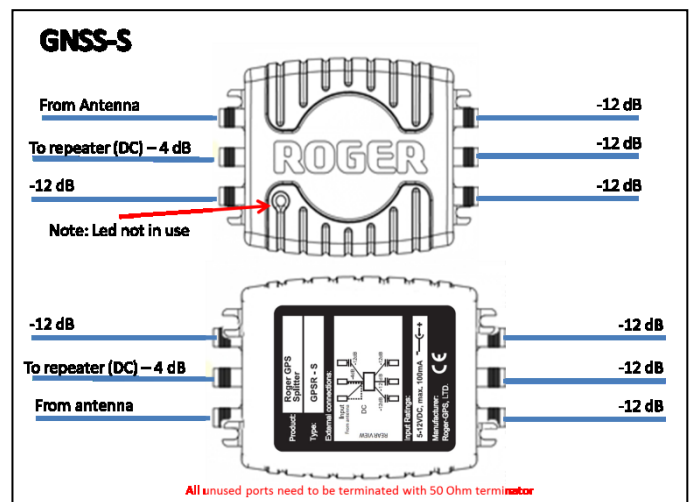

### Extending the number of repeaters by adding an Amplifier/Splitter

#### ROGER™ GNSS Amplifier & Splitter (GNSS-AS)

ROGER™ GNSS Amplifier & Splitter is a combined signal splitter and line amplifier with an output of +12dB (1 port) and +4 dB (2 ports) that can transmit to up to three separate repeater units.

In order to get the amplification, the ports must be connected as shown below. The unused ports must be terminated with a 50ohm termination if less than 3 repeaters are connected to GNSS-AS.

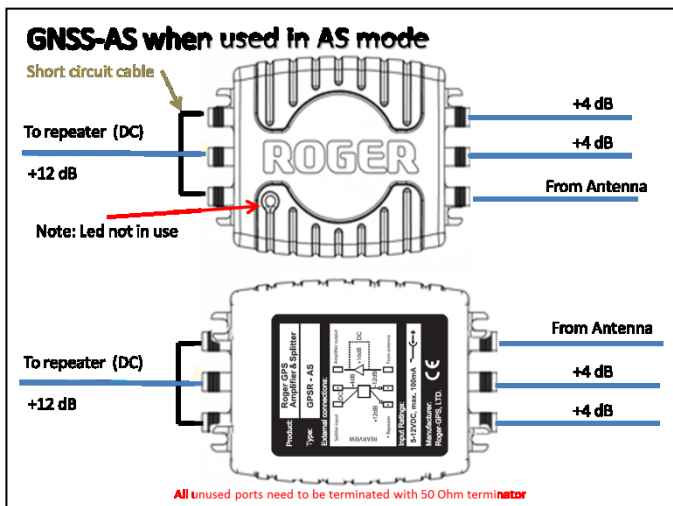

### Extending the number of repeaters by adding a Splitter 1 to 2

#### ROGER™ GNSS Splitter 1 to 2 (GNSS-S2)

With the ROGER™ GNSS Signal Splitter 1 to 2, the signal from one external antenna can be redistributed to up to two repeater units.

It is advisable to use a separate amplifier with the signal splitter to ensure adequate transmission power to all the two repeaters. If the signal is to be transmitted to only one repeater, the unused port must be terminated with a 50ohm termination. Splitter is powered through the output signal cable by the ROGER™ GNSS Repeater and it passes on DC power for the GNSS receiving antenna or GNSS line amplifier.

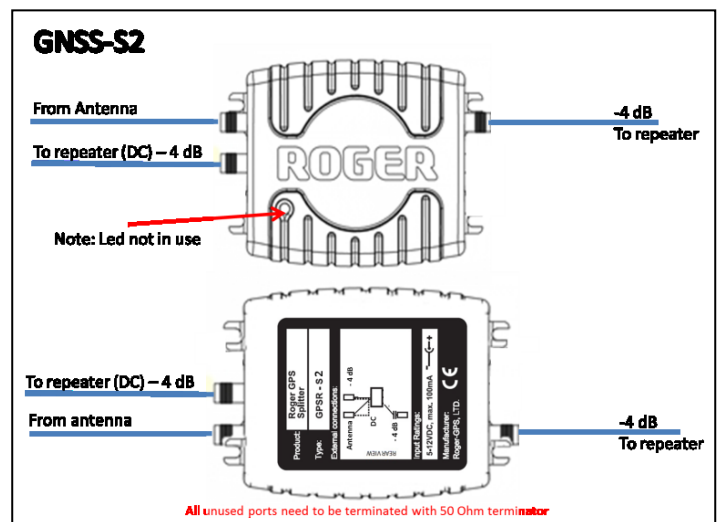

**ROGER™ GNSS-L1G1GA repeater technical information:**

<b>Size:</b>	110*143*28 mm
<b>Frequencies:</b>	GALILEO E1: 1.57542 GHz GPS L1: 1.57542 GHz GLONASS G1: 1.602 GHz BEIDOU B1: 1.5611 GHz
<b>Weight:</b>	165 g
<b>Overall Gain:</b>	> 40dB
<b>Noise Figure:</b>	< 2dB
<b>Variable attenuation:</b>	0-40dB
<b>Impedance:</b>	50Ω
<b>RF Input connector:</b>	SMA-female
<b>Power consumption:</b>	max 300 mA
<b>Operating temperature:</b>	-25 ... +55°C
<b>Power supply:</b>	110-230VAC/+12VDC, 1600mA
<b>Antenna power output:</b>	+5VDC, 100mA
<b>TX antenna gain:</b>	max +4dBd, RHCP polarization
<b>Indoor coverage radius:</b>	1-50m (depends of the sensitivity of the receiver) and the gain position
<b>Other features:</b>	Automatic gain control
	Feedback oscillation suppression Status/power LED
	Output power limit -60dBm, 0,000001mW
	Manual gain control
	Internal transmit antenna
<b>CE-certified</b>	Yes

More information about GNSS specification, look at:

- <http://www.gps-repeating.com/>
- [http://www.etsi.org/deliver/etsi\\_en/302600\\_302699/302645/01.01.01\\_60/en\\_302645v010101p.pdf](http://www.etsi.org/deliver/etsi_en/302600_302699/302645/01.01.01_60/en_302645v010101p.pdf)

## GNSS Technology Expert

# ROGER™-GPS

Roger-GPS Ltd  
Finnooniitynkuja 4  
02270 Espoo, Finland  
[www.gps-repeating.com](http://www.gps-repeating.com)

### WARRANTY

Roger-GPS Ltd agrees that any hardware supplied under these Conditions shall be free from defects in materials and workmanship for a period of 24 months from the date of the delivery "(the Warranty Period)" covering material and workmanship. The 24 months period is calculated from the date, the products are shipped from the Buyer's warehouse in the case that the Buyer has an accounting system that keeps track on the shipment dates. Nevertheless, the warranty period cannot exceed in any circumstances 26 months from the date of delivery from Roger-GPS Ltd warehouse.

Roger-GPS Ltd undertakes to remedy all defects in the Products notified to it by the Buyer during the Warranty Period by either repairing or replacing or refunding at Roger-GPS Ltd.'s option the defective Product or defective part at Roger-GPS Ltd.'s cost.

Goods returned under this guarantee shall be delivered to Roger™-GPS Ltd at the Buyer's expense. Before shipping the products to Roger™-GPS Ltd, the buyer must follow the instructions (*Roger-GPS RMA procedure*) given by Roger™-GPS Ltd and the inward processing directives set by the Finnish Customs.

Warranty will be void in respect of goods which in Roger-GPS Ltd.'s reasonable opinion, have been subjected to unauthorised modification or repair, improper installation, neglect, misuse or operation in environmental conditions outside of specified safe operating extremes. The warranty applicable to non-Roger™-GPS Ltd product supplied by Roger™-GPS Ltd shall be limited to the warranty terms offered by the manufacturer of the product.

Roger-GPS Ltd shall not be liable to the Buyer for any consequential loss.

No warranties, expressed or implied, including but not limited to, any implied warranty of merchantability of fitness for any purpose, are made or deemed to have been made by the Roger-GPS Ltd.

Roger-GPS Ltd shall not be responsible to the Buyer or any other party in respect of any claims arising out of the sale of the products. Roger-GPS Ltd does not warrant the software delivered under these conditions per se but agrees to maintain the software for a period of 90 days from the date of delivery of the relevant software.

The Buyer shall indemnify Roger-GPS Ltd against all proceedings, claims or demands in any way connected with the Conditions brought or threatened against Roger-GPS Ltd by a third party except to the extent that Roger-GPS Ltd is liable to the Buyer under the Conditions.



Supplier reserves all rights for product changes and upgrades.  
Pictures and texts are indicative