



UV/IR² Flame Detector

FUNCTION

The UV/IR² Flame Detector is designed to protect areas where open flaming fires may be expected.

FEATURES

The UV/IR² Flame Detector is sensitive to low frequency, flickering infra-red and UV radiation emitted by flames during combustion.

The UV/IR² Flame Detector is set to respond to low-frequency flickering infra-red (0.75 to 2.7 μ m) radiation at 1 to 15Hz along with UV (185nm to 260nm) in order to detect almost all flames, including those invisible to the naked eye, e.g. hydrogen fires.

The UV/IR² Flame Detector has two IR sensors that respond to different IR wavelengths in order to discriminate between flames and spurious sources of radiation. False alarms from flickering sunlight, arc welding or lightning are avoided by this combination of UV and dual IR signal processing techniques.

ELECTRICAL CONSIDERATIONS

The UV/IR² Flame Detector signals an alarm state by switching an alarm latch on, increasing the current drawn from the supply from 8mA to 28mA and closing the contacts of a Fire relay RL1. These signals from the detector are recognised by the control panel as an alarm signal.



Part no: 55000-064
UV/IR² Flame Detector

The alarm current also illuminates the detector integral red LED. A Fault relay RL2 closes its volt free contacts if the detector has no faults and the supply voltage to the detector is the correct value.



Overseas offices:

America China Germany Ireland Spain

© Apollo Fire Detectors Limited 2014

36 Brookside Road, Havant,
Hampshire, PO9 1JR, UK.

A HALMA COMPANY

Tel: +44 (0)23 9249 2412
Fax: +44 (0)23 9249 2754

Email: sales@apollo-fire.co.uk
Web: www.apollo-fire.co.uk

To ensure correct operation of the detector the control panel must be arranged to supply a maximum of 30 volts DC and a minimum of 14 volts DC in normal operation.

To restore the detector to quiescent condition after indicating a fire, it is necessary to extinguish any flames in view and interrupt the electrical supply to the detector for a minimum of one second. Removing the detector front cover provides access to the detector terminals and configuration DIL switch. The detector is normally configured to latch into an alarm state when a flame is in view. The configuration DIL switch within the detector can be set to place the detector into a non-latching mode. The detector can then also produce proportional analogue current alarm signals i.e. 8-28mA or 4-20mA. In non-latching mode the detector only produces an alarm signal when a flame is in view resetting itself to normal a few seconds after the flame has gone.

Selectable Options	DIL Switch Settings	
Relay RL2 Function:	1	2
RL2 Off	0	0
UV fire or pre-alarm	1	0
IR fire or pre-alarm	0	1
Fault (Energised if OK)	1	~ 1
Alarm Currents [RL1 Flame Relay]	3	4
3/9mA RL1 Only, 4/8/14mA RL2 & RL1	0	0
4-20mA, 4/20mA, No Relays	1	0
/or		
8-20mA, 8/20mA, & Relays	0	1
- Proportional		
8/28mA, & Relays	1	~ 1
Output Mode:	5	
Non-latching (-)	0	
Latching (/)	~1	
Response Time:	6	7
Slowest ≈ 8s	0	0
Medium ≈ 4s	1	~ 0
Fast ≈ 2s	0	1
Very Fast ≈ 1s	1	1
Sensitivity:	8	
Low	0	
High	~1	

Table 1

ACCESSORIES

A range of accessories and test equipment is available for the UV/IR² Flame Detector:

Weathershield, part no 29600-206, (see Fig. 5) Flame Sensor Test Unit and case, part no 29600-226. Stainless steel 2 axis adjustable mounting bracket, part no 29600-203

* For a full list of applications for Apollo Flame Detectors, please refer to PP2409, available on request.

TECHNICAL DATA

Mechanical			
Housing Material:	Die Cast Zinc Alloy (ZA12)		
Housing Colour:	Blue		
Dimensions:	See Fig. 3&5		
Weight:	1kg		
Cable Gland Entries:	2 x 20mm		
Electrical			
Supply Voltage:	14 to 28Vdc		
Supply Current:	See DIL switch settings		
Power Up Time:	2 seconds max.		
Test Signal Voltage:	14 to 28Vdc		
Relay Contact Ratings:		Current	0.25Amp. Max.
		Voltage	30Vdc. Max.
Resistive Loads Only		Power	3.0W Max.
Performance			
Range:	0.1m ² n-heptane at 25m		
(See EN54-10)	0.2m ² n-heptane at 35m		
	0.4m ² n-heptane at 45m		
Field of View:	90° min. Cone		
Spectral Response:		UV	185 to 260nm
		IR	0.9 to 1.7µm
Sensitivity:			High = Class 1
(See EN54-10)			Low = Class 2
Environmental			
Operating Temperature:	-10°C to 85°C		
Storage Temperature:	-20°C to 65°C		
Relative Humidity:	95% Non condensing		
IP Rating:	IP65		
EMC Immunity:	EN 50081-1, EN 50081-2		
	EN 50082-2, EN 50082-2		
	EN 50130-4, EN 550		

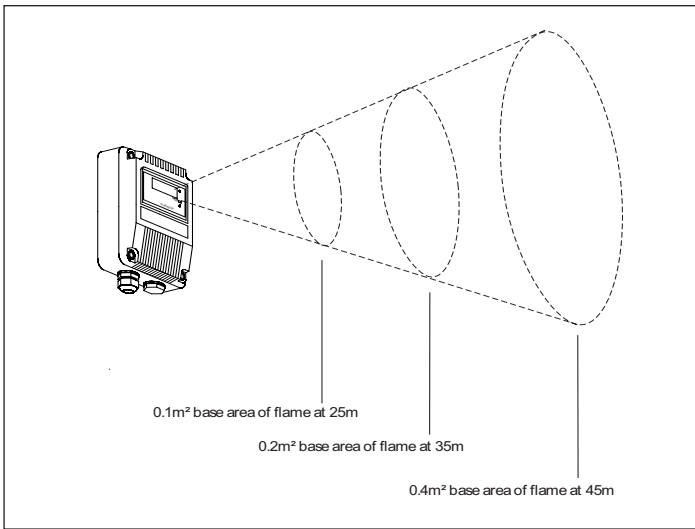

Fig 1 Flame detection as a function of flame size and distance from detector

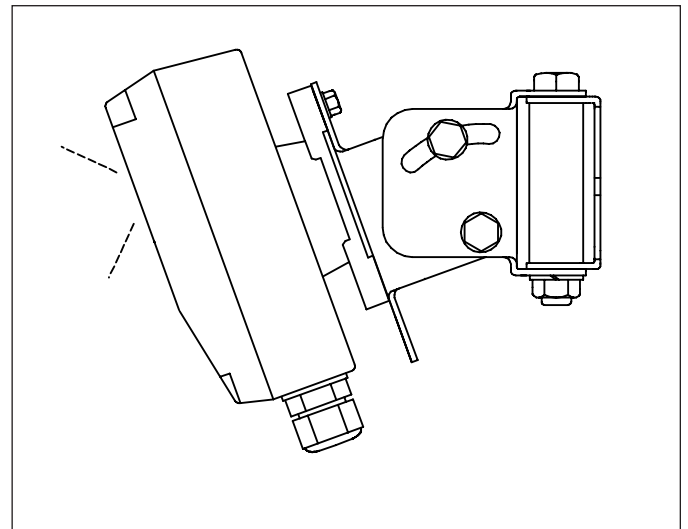

Fig 4 IR² Flame Detector on stainless steel 2 axis adjustable mounting bracket (Part no 29600-203)

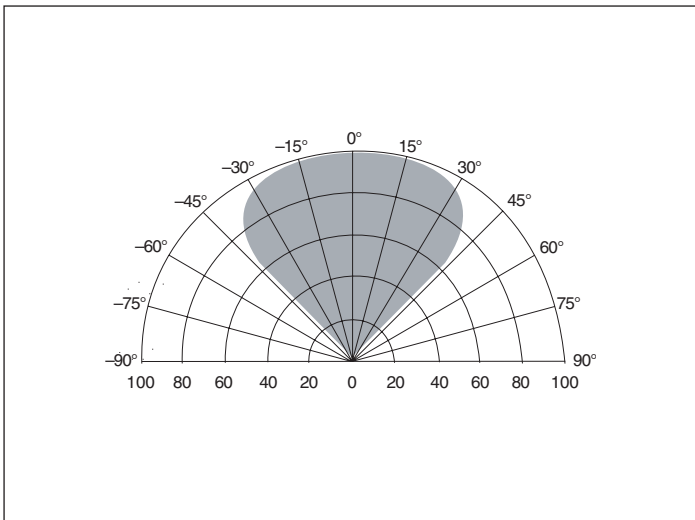

Fig 2 Angle of view of Flame Detector

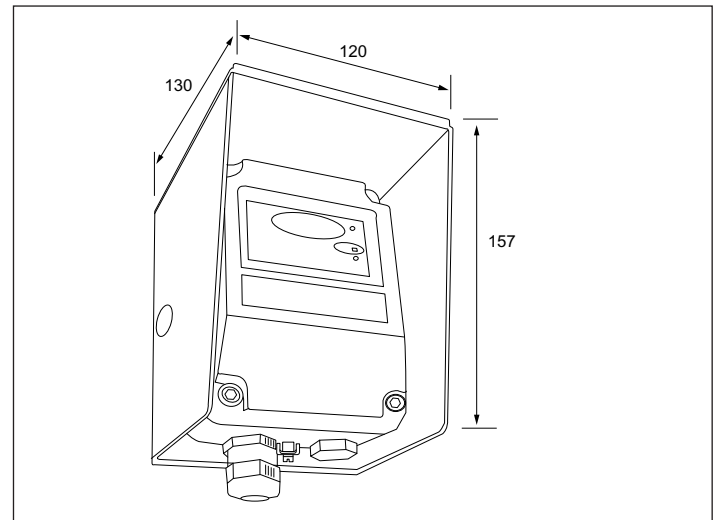

Fig 5 IR² Flame Detector with Weathershield (Part no 29600-206)

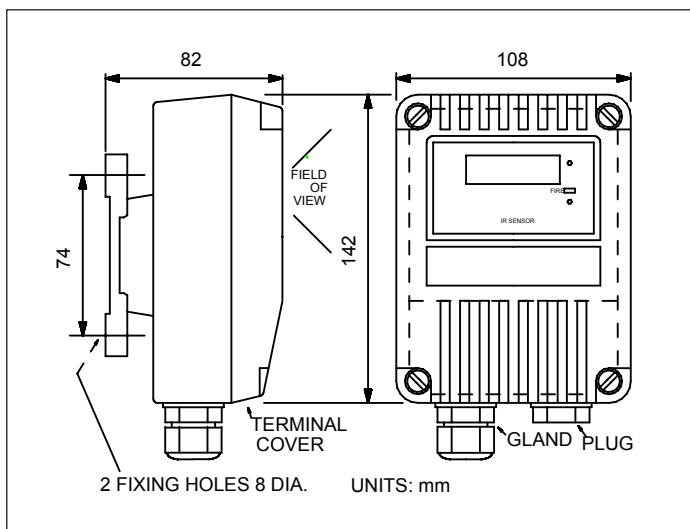

Fig 3 Front and side view to show dimensions of flame detector