

OS1 Hardware User Manual

For Rev 06 OS1 Sensors

Ouster

Jul 25, 2022

Contents

1	Important Safety Information	3
1.1	Safety & Legal Notices	3
1.2	Proper Assembly, Maintenance and Safe Use	6
1.3	Sensor Cleaning	7
2	Sensor	9
2.1	Overview	9
2.2	OS1 Product Models	9
3	Mechanical Interface	9
3.1	Included Components	9
3.2	Mounting Guidelines	11
3.3	Operating Temperatures	12
4	Electrical Interface	12
4.1	Power Supply and Operating Voltage	12
4.2	Connection through the Interface Box	12
4.3	Direct Cable Connection and Pinout	13
5	Digital IO	14
5.1	SYNC_PULSE_IN	14
5.2	MULTIPURPOSE_IO (M_IO)	16
6	OS1 CAD files	16
7	Accessories	17
7.1	Cables	17
7.2	Interfaces	19
8	GPS/GNSS Synchronization Guide	27
8.1	Setting up your GPS/GNSS	27
8.2	Connecting the Hardware	27
8.3	Configuring the Ouster Sensor	30
9	Support	30

1 Important Safety Information

1.1 Safety & Legal Notices

The OS1-128, OS1-64, and OS1-32 have been evaluated to be **Class 1 laser products** per **60825-1: 2014 (Ed. 3)** and operate in the 865nm band.

L'OS1-128, l'OS1-64, et l'OS1-32 répondent aux critères des **produits laser de classe 1**, selon la norme **IEC 60825-1: 2014 (3ème édition)** et émettent dans le domaine de l'infrarouge, à une longueur d'onde de 865nm environ.

FDA 21CFR1040 Notice: OS1-128, OS1-64, and OS1-32 comply with FDA performance standards for laser products except for deviations pursuant to Laser Notice No. 56, dated January 19, 2018.

Notice FDA 21CFR1040: L'OS1-128, l'OS1-64, et l'OS1-32 sont conformes aux exigences de performances établies par la FDA pour les produits laser, à l'exception des écarts en application de l'avis n°56, daté du 19 janvier 2018.



Figure 1.1: Class 1 Laser Product



Figure 1.2: Caution "Sharp Edges"

The following symbols appear on the product label and in the user manual have the following meaning.

CAUTIONS:



Figure 1.3: This symbol indicates that the sensor emits laser radiation.



Figure 1.4: This symbol indicates the presence of a hot surface that may cause skin burn.

- The OS1 is a hermetically sealed unit, and is non user-serviceable.
- Use of controls, or adjustments, or performance of procedures other than those specified herein, may result in hazardous radiation exposure.
- Use of the OS1 is subject to the Terms of Sale that you agreed and signed with Ouster or your distributor/integrator. Included in these terms are the prohibitions of:
 - Removing or otherwise opening the sensor housing
 - Inspecting the internals of the sensor
 - Reverse-engineering any part of the sensor
 - Permitting any third party to do any of the foregoing
- Operating the sensor without the attached mount that is shipped with the sensor, or attaching the sensor to a surface of inappropriate thermal capacity runs the risk of having the sensor overheat under certain circumstances.
- This lidar sensor features a modular cap design to enable more flexible mounting and integration solutions for the sensor.
- The modular cap design increases design flexibility but it does not remove the need for thermal management on top of the sensor. The attached radial cap serves an important thermal management purpose and the sensor will not operate properly without a cap.
- Operation for extended periods of time without the cap will result in system errors and the sensor overheating. The cap can be replaced with alternative solutions but it cannot be left off altogether.
- If you wish to operate the sensor with a custom mounting solution, please contact our [Field Application Team](#) and we can answer your questions and provide guidance for achieving proper operations.
- This product emits Class 1 invisible laser radiation. The entire window is considered to be the laser aperture. While Class 1 lasers are considered to be “eye safe”, avoid prolonged direct view-

ing of the laser and do not use optical instruments to view the laser.

- When operated in an ambient temperature $>40\text{ }^{\circ}\text{C}$, the metallic surfaces of the sensor may be hot enough to potentially cause skin burn. Avoid skin contact with the sensor's base, lid and the heatsink when the sensor is operated under these conditions. The sensor should not be used in an ambient temperature above 60°C . The maximum safety certified ambient operating temperature is 60°C .

PRECAUTIONS:

- L'OS1 est une unité hermétiquement scellée, qui ne peut être entretenue ou modifiée par l'utilisateur.
- L'utilisation de commandes, de réglages, ou l'exécution de procédures autres que celles spécifiées dans le présent document peuvent entraîner des rayonnements laser dangereux.
- L'utilisation de l'OS1 est soumise aux conditions de vente signées avec Ouster ou le distributeur/intégrateur, incluant l'interdiction de:
 - Retirer ou ouvrir de quelque façon le boîtier du capteur
 - Analyser les composants internes du capteur
 - Pratiquer la rétro-ingénierie de toute ou partie du capteur
 - Autoriser une tierce personne à mener les actions listées ci-dessus
- L'utilisation du capteur sans le support (fourni avec le capteur) ou sans contact avec une surface ayant des capacités thermiques adéquates peut entraîner une surchauffe du capteur dans certaines conditions.
- Ce capteur présente une conception avec un dissipateur thermique supérieur modulaire, ceci pour apporter plus de flexibilité de montage et d'intégration au capteur.
- Cette conception modulaire augmente la flexibilité de conception mais ne supprime pas le besoin de dissipation thermique au-dessus du capteur. Le dissipateur thermique radial fourni est essentiel à une bonne gestion thermique. Le capteur ne fonctionnera pas correctement sans cette pièce.
- Une utilisation prolongée du capteur sans le dissipateur thermique supérieur peut résulter à des erreurs système ainsi qu'à une surchauffe du capteur pouvant aller jusqu'à son extinction. Le dissipateur thermique fourni peut être remplacé par une autre solution de dissipation thermique adéquate, mais ne doit pas être simplement retiré.
- Si vous souhaitez utiliser votre capteur avec une dissipation thermique personnalisée, merci de contacter notre [Équipe Support](#) qui pourra répondre à vos questions et vous apporter le support et le conseil nécessaire.
- Ce produit émet un rayonnement laser invisible de classe 1. L'ouverture de sortie du laser est constituée par la fenêtre du capteur dans sa totalité. Même si les lasers de classe 1 ne sont pas considérés comme dangereux pour les yeux, ne regardez pas directement le rayonnement laser de façon prolongée et n'utilisez pas d'instruments optiques pour observer le rayonnement laser.
- Lors d'une utilisation à température ambiante supérieure à 40°C , la surface métallique du cap-

teur peut présenter des risques de brûlures pour la peau. Dans ces conditions, il est important d'éviter tout contact avec la partie supérieure, la base ou le dissipateur thermique du capteur. Le capteur ne doit pas être utilisé à une température ambiante supérieure à 60°C. 60°C est la température maximale certifiée d'opération sûre du capteur.

Equipment Label: Includes model and serial number and a notice that states the unit is a Class 1 Laser Product, is affixed to the underside of the Sensor Enclosure Base. It is only visible after the attached mount with which the Sensor is shipped, is removed. For location details please refer to figure [Sensor Components](#) in the Mechanical Interface Section.

L'étiquette de l'équipement, comprenant le modèle, le numéro de série, et la classification du produit laser (ici, classe 1), est apposée au-dessous de la base du boîtier du capteur. Il n'est visible qu'après avoir retiré le diffuseur de chaleur avec lequel le capteur est expédié. L'emplacement est décrit avec précision dans la section [Sensor Components](#).

Electromagnetic Compatibility: The OS1 is an FCC 47 CFR 15 Subpart B device. This device complies with part 15 of the FCC Rules. Operation is subject to the following conditions: (1) This device may not cause harmful interference, and (2) this device must accept any interference received, including interference that may cause undesired operation.

"Ouster" and "OS1" are both registered trademarks of Ouster, Inc. They may not be used without express permission from Ouster, Inc.

If you have any questions about the above points, contact us at legal@ouster.io.

1.2 Proper Assembly, Maintenance and Safe Use

The OS1 can be easily set up by following the instructions outlined in [Mounting Guidelines](#). Any mounting orientation is acceptable. Each sensor is shipped with an attached mount that can be used for test or normal use within the specified operating conditions. The sensor may also be affixed to any other user specific mount of appropriate thermal capacity. Please contact Ouster for assistance with approving the use of user specific mounting arrangements.

Any attempt to utilize the sensor outside the environmental parameters delineated in the OS1 datasheet may result in voiding of the warranty.

When power is applied, the sensor powers up and commences boot-up with the laser disabled. The boot-up sequence is approximately 60s in duration, after which the internal sensor optics subassembly commences spinning, the laser is activated, and the unit operates in the default 1024 x 10 Hz mode. When the sensor is running, and the laser is operating, a faint red flickering light may be seen behind the optical window.

Note that the OS1 utilizes an 865nm infrared laser that is only dimly discernible to the naked eye. The sensor is fully Class 1 eye safe, though Ouster strongly recommends against peering into the optical window at close range while the sensor is operating. Ouster sensors are equipped with a multi-layer series of internal safety interlocks to ensure compliance to Class 1 Laser Eye Safe limits.

The OS1 is a hermetically sealed unit, and is not user-serviceable. Any attempt to unseal the enclosure has the potential to expose the operator to hazardous laser radiation.

The sensor user interface may be used to configure the sensor to a number of combinations of scan

rates and resolutions other than the default values of 1024 x 10 Hz resolution. In all available combinations, the unit has been evaluated by an NRTL to remain within the classification of a Class 1 Laser Device as per IEC 60825-1:2014 (Ed. 3).

Assemblage correct et utilisation sûre

L'OS1 s'installe facilement en fixant la base sur un support percé de trous concordants, et en suivant les instructions d'interconnexion décrites dans la section [Mounting Guidelines](#). Toute orientation de montage est acceptable. Chaque capteur est expédié équipé d'un dissipateur de chaleur, utilisable en phase de test et en conditions normales. Néanmoins tout autre support présentant une capacité thermique appropriée pour l'application de l'utilisateur peut être utilisé. Veuillez contacter Ouster dans le cas où un montage spécifique à votre application serait nécessaire.

Toute tentative d'utilisation du capteur en dehors des paramètres environnementaux définis dans la fiche technique de l'OS1 peut entraîner l'annulation de la garantie.

Lorsque le capteur est sous tension, celui-ci démarre et commence son initialisation avec le laser dés-activé. Le temps de démarrage est d'environ 60s, après quoi le sous-système optique entre en rotation et le laser est activé, le capteur opère alors dans son mode par défaut de 1024 x 10 Hz. Lorsque le capteur est en marche et que le laser est activé, on peut apercevoir une faible lumière rouge vacillante derrière la vitre teintée. L'OS1 utilise une longueur d'ondes infra-rouge de 865nm nm à peine perceptible pour l'œil humain, et le rayonnement laser IR émis est sans danger pour les yeux. Cependant, bien que les rayonnements laser de classe 1 soient sans danger dans des conditions raisonnablement prévisibles, Ouster recommande fortement de ne pas regarder fixement la vitre teintée pendant que le capteur est en marche. L'OS1 est une unité hermétiquement scellée, qui ne peut pas être entretenue, modifiée ou réparée par l'utilisateur. Toute tentative d'ouverture du boîtier a pour risque d'exposer l'opérateur à un rayonnement laser dangereux.

L'OS1 est une unité hermétiquement scellée, qui ne peut pas être entretenue, modifiée ou réparée. Toute tentative d'ouverture du boîtier a pour risque d'exposer l'opérateur à un rayonnement laser dangereux.

Les capteurs Ouster sont équipés d'une série de dispositifs de sécurité à plusieurs niveaux, de façon à assurer en toutes circonstances le respect des limites d'irradiance correspondant aux rayonnements lasers de classe 1, sans danger pour les yeux.

L'interface utilisateur du logiciel du capteur peut être utilisée pour configurer le capteur selon un certain nombre de combinaisons de vitesses de balayage et de résolutions autres que les valeurs utilisées par défaut, respectivement de 1024 x 10 Hz.

1.3 Sensor Cleaning

All Ouster Sensor window are made from polycarbonate. Based on the sensor usage you may see dust, bugs and/or layers of mud/debris on the window. Before you attempt to clean your sensor, please read the instructions below on best practices for cleaning Ouster Sensors.

Required Materials:

- Few clean microfiber cloths

- Warm water
- Mild liquid dishwashing soap
- Spray bottle with clean water
- Spray bottle with mild soapy water
- 99% Isopropyl alcohol

Warning:

- Avoid getting water into the power connector.
- Avoid using hard water when cleaning the sensor.
- Do not use acetone to clean the window. It will embrittle the polycarbonate.
- Do not wipe dirt directly from the sensor. Spray it off with warm water first.

Procedure:

- Using the 99% isopropyl alcohol and a clean microfiber towel, wipe away bugs/mud/debris from the sensor.
- Spray the sensor with warm, mild-soapy water and gently wipe the sensor with a clean microfiber towel. Wipe along the curve of the sensor, not top-to-bottom (think moving with the grain).
- Spray the sensor with clean water to rinse off the soap and dry with a second microfiber towel.
- Enjoy your clean window.

2 Sensor

2.1 Overview

The OS1 offers an industry-leading combination of price, performance, reliability, size, weight, and power. It is designed for indoor/outdoor all-weather environments and a long operating lifetime.

The OS1 family of sensors consist of three models, the OS1-128, OS1-64, and OS1-32, with differing vertical resolution, but identical mechanical dimensions.

For the purposes of this document, the term "OS1" refers to the family of sensors, and only where there is a difference in performance will each model be referred to by its specific model designation.

The contents of this manual are applicable only to Rev 06 sensors. Please contact support@ouster.io with the sensor serial number to find out your sensor Rev information. For all other sensor hardware revisions, please refer to the respective hardware user manual found [Here](#).

2.2 OS1 Product Models

The OS1 is available with 128, 64, or 32 beams of vertical resolution and with Uniform, Gradient, Above Horizon, or Below Horizon beam spacing options. Product specs and more information on these configurations can be found on the [OS1 product page](#).

3 Mechanical Interface

3.1 Included Components

The OS1 is shipped with the following items:

- OS1-128, OS1-64, or OS1-32
- Sensor to Interface Box cable/connector
- Interface Box and 24V AC/DC power supply (2 meters)
- RJ45 cable (1 meter)
- Baseplate Mount

Downloadable CAD files for the OS1 can be found online at [Ouster Download Page](#)

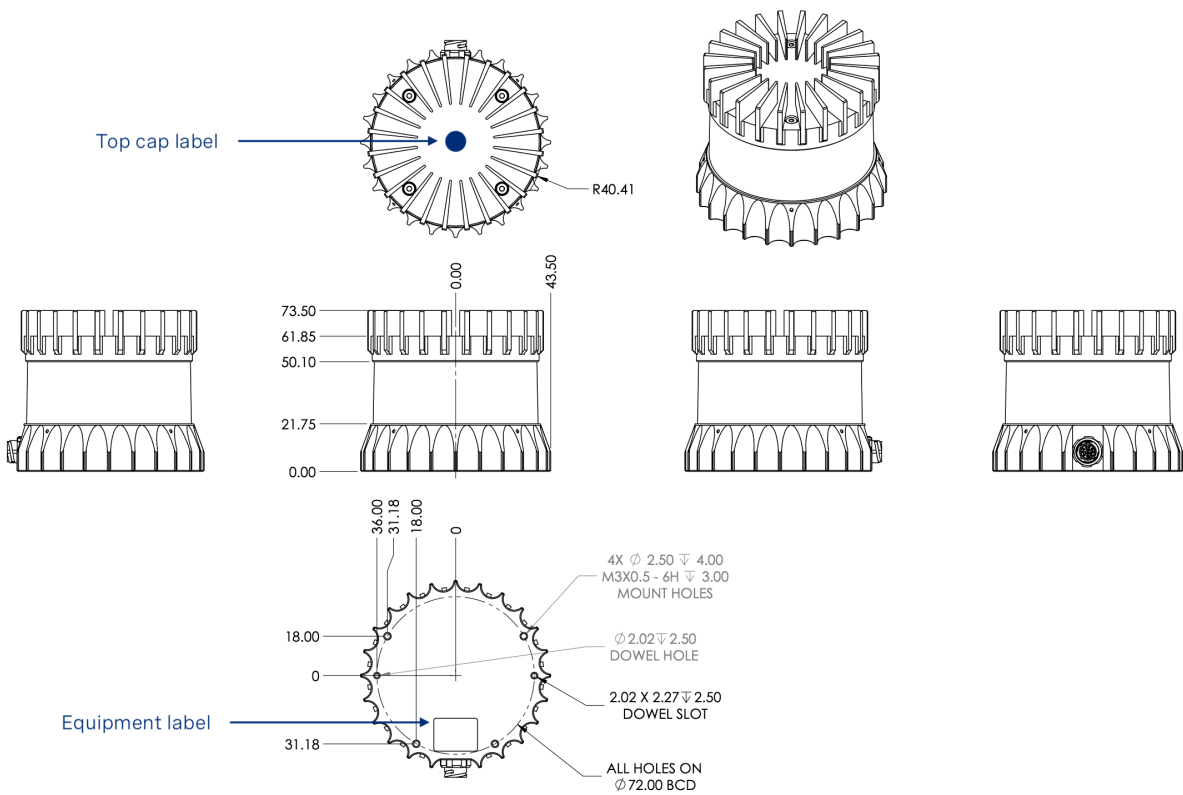

Figure 3.1: Sensor Components

Warning: The water ingress protection rating for the sensor is only valid if the I/O cable is plugged into the panel mount connector on the base of the sensor, and the locking collet rotated past the détente click to the properly locked condition i.e past the détente position. The cable and plug are an element of the sensor ingress protection system. Without the connected cable the ingress protection rating may be compromised. Bending the cable at a sharp angle directly after egress from the plug over mold should also be avoided. Sharp bends and high axial stresses on the cable immediately adjacent to the plug over mold may create a moisture ingress path into the connector. Please note the cable minimum bend radius requirements below:

3.2 Mounting Guidelines

Our sensors ship with modular mounting options. The sensor can be mounted in any orientation. Proper mounting will ensure optimal sensor performance, reducing noise from vibration and providing efficient heat dissipation.

- Mount to a material with high thermal conductivity. The following are recommended aluminum alloys and their thermal conductivity:

1) 6061: 167 W/m-K

2) 7075: 130 W/m-K

3) 2024: 121 W/m-K

- Ensure interfaces are clean and free from debris.
- M3 screws are recommended for mounting the sensor. The screw hole pattern is presented in the Sensor drawing above [Sensor Components](#).
- Torque bolts appropriately for the mount material and bolts. A torque of 146cNm is recommended for a2 stainless steel screws.
- Use TIM (Thermal Interface Material) for any irregular or unmachined surfaces.
- Do not overconstrain the sensor if mounting to both the top and the bottom.
- Use a thermally conductive pad to ensure good conductivity while not over constraining.
- Ensure your implementation maintains the base and top of the sensor at no greater than 25°C above ambient with an ambient less than 50°C.
- The shape of any heatsink should maximize the surface area for free and forced convection while being thick enough to allow the heat to conduct through the material.

If you have questions about your specific mounting situation please contact the Ouster at support@ouster.io.

3.3 Operating Temperatures

Thermal requirements specific to Rev 06 are listed below. The sensor has three operating states in order to manage high temperatures: Active, Shot Limiting, or Inactive. In the standard Active state the sensor will perform to the range and precision specifications of the datasheet. When the sensor reaches a certain temperature (see table below for reference), it enters Shot Limiting state and issues an alert. In Shot Limiting state, the sensor reduces power to the lasers in order to reduce the thermal load. While in this state, sensor range and precision may degrade by up to 20%. When the sensor reaches the maximum operating temperature specified below, the sensor may become Inactive and shut off.

Please contact support@ouster.io with your sensor serial number to find out your sensor revision.

Table 3.1: Maximum thermal performance for Rev 06 OS1 Sensor

	Convective Air Temp with Radial Heatsink and Standard Base
Max temp before shot limiting	52°C
Temp that shot limiting saturated (sensor may turn off above this temperature)	60°C

4 Electrical Interface

4.1 Power Supply and Operating Voltage

The OS1 Rev 06 Sensors are meant to operate at 12V and 24V nominal input voltage. A low voltage warning will be triggered if the voltage at the sensor connector drops below 9.5V. The sensor will shut down if this input voltage drops to 9V. The maximum input voltage is 34V for the OS1 sensor. When used without the provided interface box, ensure that the power supply is compliant with the operating voltage specified above and allows to supply at least 20 W.

4.2 Connection through the Interface Box

The Interface Box that accompanies the OS1 is designed to allow the sensor to be operated for test and evaluation purposes in indoor environments only. It can be connected to the sensor with a cable equipped with connectors on both ends. It allows the sensor to be powered up and provides access to the sensor gigabit Ethernet Interface via a standard RJ45 connector. DC Power to the sensor is provided to the Interface Box by the accompanying 24V DC power supply.

4.3 Direct Cable Connection and Pinout

The OS1 can be operated without the use of an Interface Box. In this case, a “pigtail” cable should be used and wires should be connected by the user following the Pinout presented below. When used with direct cable connection, the sensor should still be operated within the operating voltage specified in section [Power Supply and Operating Voltage](#)

Warning: Ouster is not responsible for any errors in wiring as a result of bypassing the Interface Box and this activity may result in a voiding your warranty if it results in damage to the sensor. The following guidelines for direct cable connection assume use of the Ouster-provided 24V 1.5A power supply. Ouster cannot be held responsible for damage to the device if alternate is used.

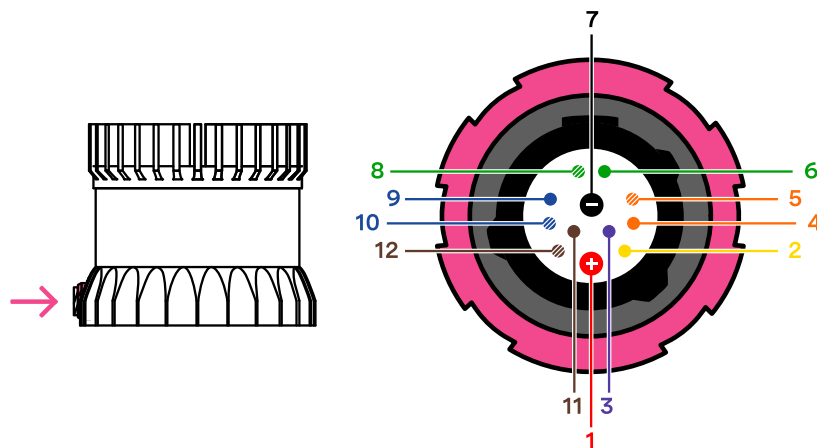

Figure 4.1: Cable pinout of on-sensor receptacle

Table4.1: Cable pinout wires

Net Name	Pin Number	Wire Color	Wire AWG (Type-1, 24V)	Wire AWG (Type-2, 24V)	Wire AWG (Type-3, 12V)	Twisted With
MULTIPURPOSE_IO	3	Purple	26 AWG	28 AWG	28 AWG	N/A
SYNC_PULSE_IN	2	Yellow	26 AWG	28 AWG	28 AWG	N/A
VCC	1	Red	22 AWG	22 AWG	18 AWG	N/A
GROUND	7	Black	22 AWG	22 AWG	18 AWG	N/A
TRP_1_P (Ethernet)	5	White/Orange	26 AWG	28 AWG	28 AWG	Orange
TRP_1_N (Ethernet)	4	Orange	26 AWG	28 AWG	28 AWG	White/Orange

continues on next page

Table 4.1 - continued from previous page

Net Name	Pin Number	Wire Color	Wire AWG (Type-1, 24V)	Wire AWG (Type-2, 24V)	Wire AWG (Type-3, 12V)	Twisted With
TRP_2_P (Ethernet)	8	White/-Green	26 AWG	28 AWG	28 AWG	Green
TRP_2_N (Ethernet)	6	Green	26 AWG	28 AWG	28 AWG	White/-Green
TRP_3_P (Ethernet)	9	Blue	26 AWG	28 AWG	28 AWG	White/Blue
TRP_3_N (Ethernet)	10	White/Blue	26 AWG	28 AWG	28 AWG	Blue
TRP_4_P (Ethernet)	12	White/Brown	26 AWG	28 AWG	28 AWG	Brown
TRP_4_N (Ethernet)	11	Brown	26 AWG	28 AWG	28 AWG	White/Brown

5 Digital IO

5.1 SYNC_PULSE_IN

SYNC_PULSE_IN is a dedicated input channel that is accessible within the Interface Box Jumper J4. This channel expects an input pulse sequence which can be used for time synchronization. Refer to the Software User Manual for more information on configuring this input. Any references to pulse polarity in this document references the signal polarity on the **SYNC_PULSE_IN** pin of the sensor. This input channel is protected by an opto-isolator which will draw 5mA at full operation.

Table 5.1: SYNC_PULSE_IN Interface Requirements

Parameter	Min Voltage	Max Voltage	Min Driver Current
LOGIC LOW	-30 V	2 V	N/A
LOGIC HIGH	2.9 V	30 V	3mA @3.3V~5V, 5mA at 24V and higher

SYNC_PULSE_IN Interface requirements were tested with 2 m cable Interface Box connection at 2 MHz.

- When GPIO has 5 mA drive strength minimum, GPIO can be directly connected to the **SYNC_PULSE_IN** pin of the Interface Box header. This is the most common case and has been tested

to work on common Arduino microcontroller series. Typical common logic levels of 3.3 V, 5 V GPIO of microcontrollers can produce drive strength of 5 mA min (Arduino, MSP430, etc.).

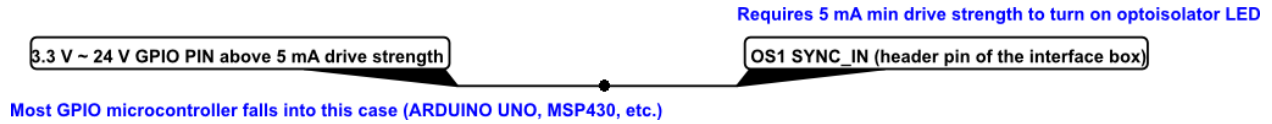

Figure 5.1: Example Circuits for 3.3 V and 5 V logic

- If the 5 mA drive strength minimum cannot be met, a buffer circuit is required to drive SYNC_PULSE_IN. Example circuits are provided for common 3.3 V and 5 V logic.

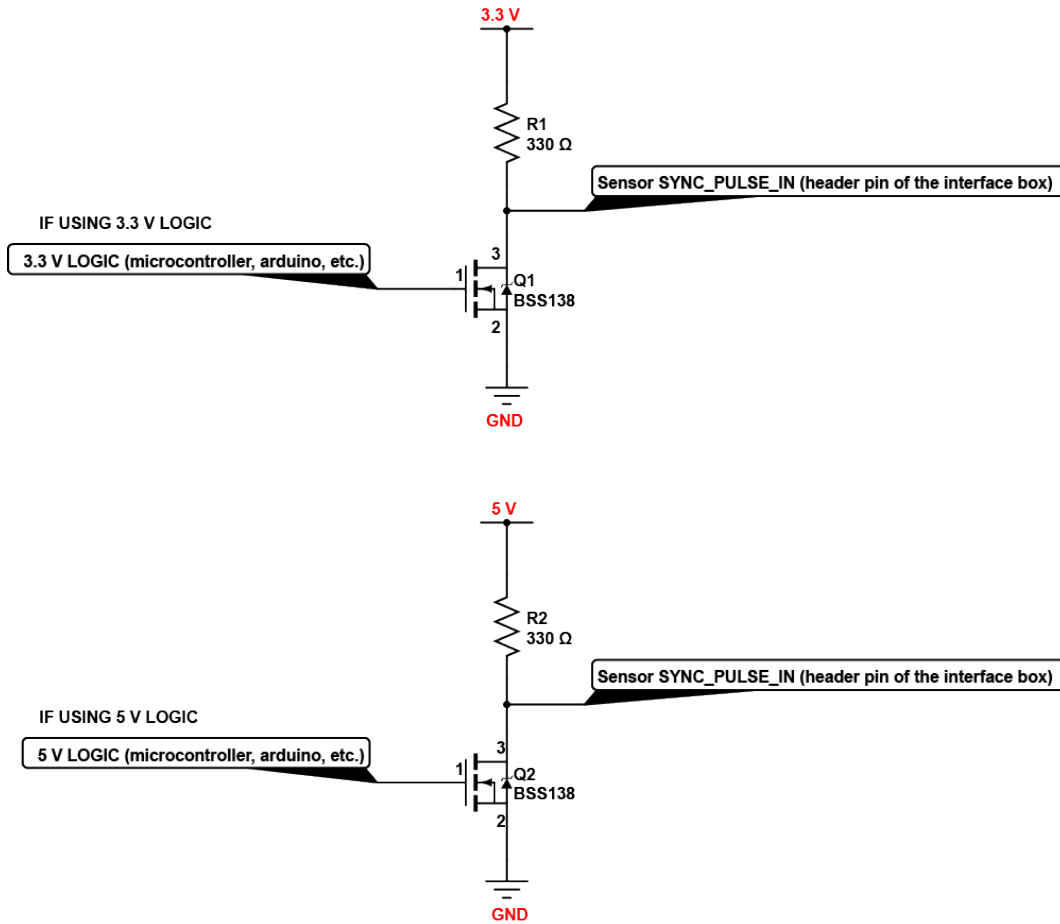

Figure 5.2: Example Circuits for 3.3 V and 5 V logic

5.2 MULTIPURPOSE_IO (M_IO)

MULTIPURPOSE_IO (M_IO) is a configurable input or output channel accessible within the Interface Box Jumper J4 connected to the MULTIPURPOSE_IO pin of the Interface Box. Detailed information on how to configure this channel using the sensor TCP interface can be found in the API Guide. By default this channel is disabled.

When this channel is configured as an **OUTPUT**, the **M_IO** sends a pulse sequence that can be used for time synchronization or event triggering outside the sensor. For a full description of output pulse triggering options, refer to the Software User Manual for more information. This output is an opto-isolated open collector circuit, relying on an externally provided pull-up resistor. This resistor is provided for a typical 3.3V/5V application as part of the Interface Box circuitry.

Table5.2: MULTIPURPOSE_IO - OUTPUT Interface Requirements

Parameter	Min	Max
Pull Up Voltage	3.3 V	24 V
Sinking Current	N/A	25 mA

When this channel is configured as an **INPUT**, the **M_IO** can accept a standard NMEA \$GPRMC UART message. These messages are a common way for GPS systems to share timestamp information in UTC time format. More information on this packet structure and supported baud rates can be found in the Time Synchronization section of the Software User Manual.

Table5.3: MULTIPURPOSE_IO - INPUT Interface Requirements

Parameter	Min Voltage	Max Voltage	Min Driver Current
LOGIC LOW	-30 V	2 V	N/A
LOGIC HIGH	2.9 V	30 V	3mA @3.3V~5V, 5mA at 24V and higher

Above are tested with 35m (200uH inductance) cable Interface Box connection at 115200 Baudrate.

6 OS1 CAD files

The most up-to-date CAD files of all our products can be found on our [Lidar Product Details](#) page.

7 Accessories

7.1 Cables

Cable Types

3 types of cables are compatible with the OS1 sensors. Their physical characteristics are presented in the table [Cable Characteristics](#).

The cable and plug are an element of the sensor ingress protection. Without this, the ingress protection rating may be compromised. Bending the cable at a sharp angle directly after egress from the plug over mold should also be avoided. Sharp bends and high axial stresses on the cable immediately adjacent to the plug over mold may create a moisture ingress path into the connection. Please note the cable minimum bend radius requirements.

Note: We no longer offer Type 1 cables for sale. Please contact your Ouster sales representative for questions regarding available cable lengths, connector types, and termination options.

Table 7.1: Cable Characteristics

Cable		Outer Diameter	Cable (Static)	Minimum Bend	Cable Minimum Bend (Flexible)
Type 1 (Thick)	1	10.5mm	79mm		158mm
Type 2 (Thin)		8mm	40mm		80mm
Type 3		8.2mm	41mm		82mm

Note: Type 3 Cable has an imprint that states "Type 3" on it whereas, Type 2 does not have any identifiers.

Note: Ouster recommends using a right angled connector cable for use cases wherein the cable needs to be bent within the first **5 cm** between the connector and the rest of the cable.

Electrical Characteristics

Ouster has characterized the cable resistance and contact resistance of our cables at room temperature. This can be found below:

Table 7.2: Electrical Characteristics

Cable	Maximum Cable Resistance (Ω/m)	Typical End to End Resistance for 5m Cable (Ω)	Admissible Nominal Operating voltage (V)
Type 1 (Thick)	0.110	0.45	24
Type 2 (Thin)	0.110	0.45	24
Type 3	0.042	0.3	12 / 24

For full sensor functionality, a minimum of 9.5 V must reach the sensor. To compensate for losses through wire resistance, a higher voltage must be provided to the interface end of the cable, which may be the Interface Box or the pigtail wires. If the sensor is below this voltage for at least 1 second, the INPUT_VOLTAGE_LOW error will be triggered.

The following graph can be used as a guide to determine the appropriate input voltage to the sensor connector for your desired cable length. The values on the graph were calculated using idealized cable resistances derived from the AWG system and assumed maximum power draw from the sensor.

Voltage at Interface Connector vs. Cable Length to achieve 9.5 V at the Sensor

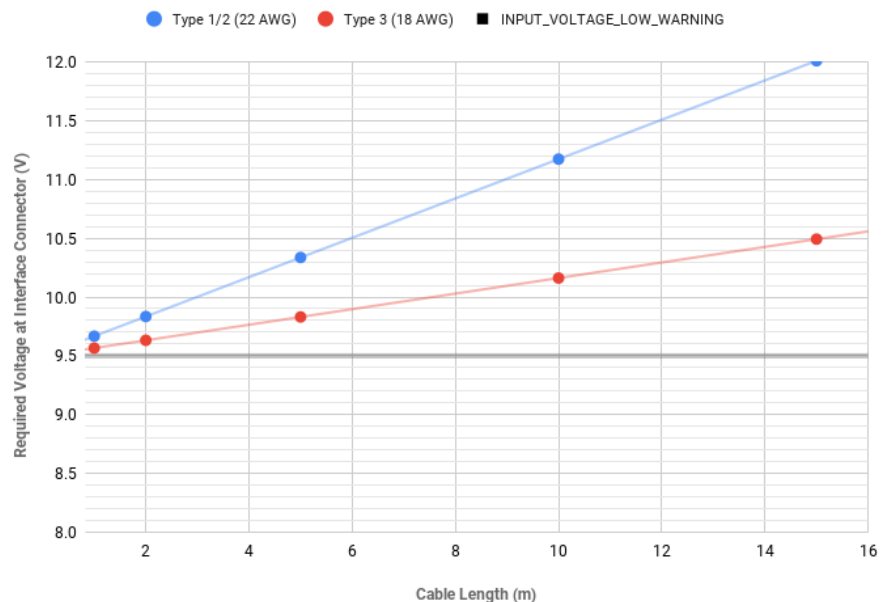

7.2 Interfaces

All Interface Boxes are provided with a DC power port and an 8-pin modular jack for Ethernet. Currently Ouster offers two types of Interface boxes to support both 12V and 24V.

Interface Boxes (Standard) provided with Type 1 and Type 2 cables are assembled with integral cables for connection to Ouster's sensors. This cable cannot be disconnected from the interface box, as there is no connector available.

The Interface Boxes (12V Compatible) with Type 3 cables are provided with an output connector and a separate connectorized cable for connection to Ouster's sensors. These Interface Boxes also have a new GPS input connector capable of accepting operating TTL levels originating in a separate GPS device containing static electricity dissipation circuitry.

Example: GPS Module compatible with Ouster Sensor [GPS Module](#).

Note: If you need support to configure the GPS to works with our sensor please contact support@ouster.io.

Warning: RISK OF FIRE OR ELECTRIC SHOCK. DO NOT CONNECT THE GPS CONNECTOR DIRECTLY TO AN ANTENNA.

7.2.1 Interface Box 24V Compatibility (Standard)

The Interface Box that accompanies the OS1 is designed to allow the sensor to be operated for test and evaluation purposes. It terminates the interface cable from the sensor, allows it to be powered up and provides access to the sensor gigabit Ethernet Interface via a standard RJ45 connector. DC Power to the sensor is provided to the Interface Box by the accompanying 24V DC Supply.

Note: The Ouster Interface Box is a support tool for use in laboratory environments to assist customers in evaluating Ouster's LiDAR sensor products and in the development of software. The Interface Box is not protected from ingress of moisture or solid particles and is not intended for use outdoors.

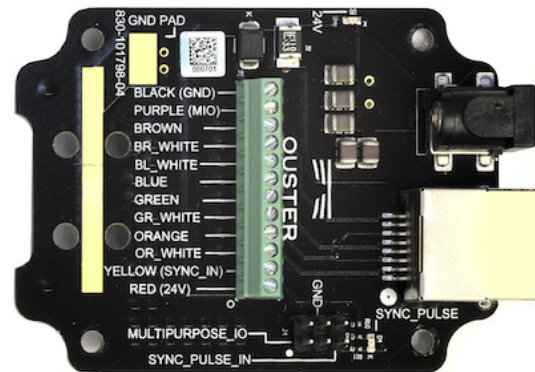
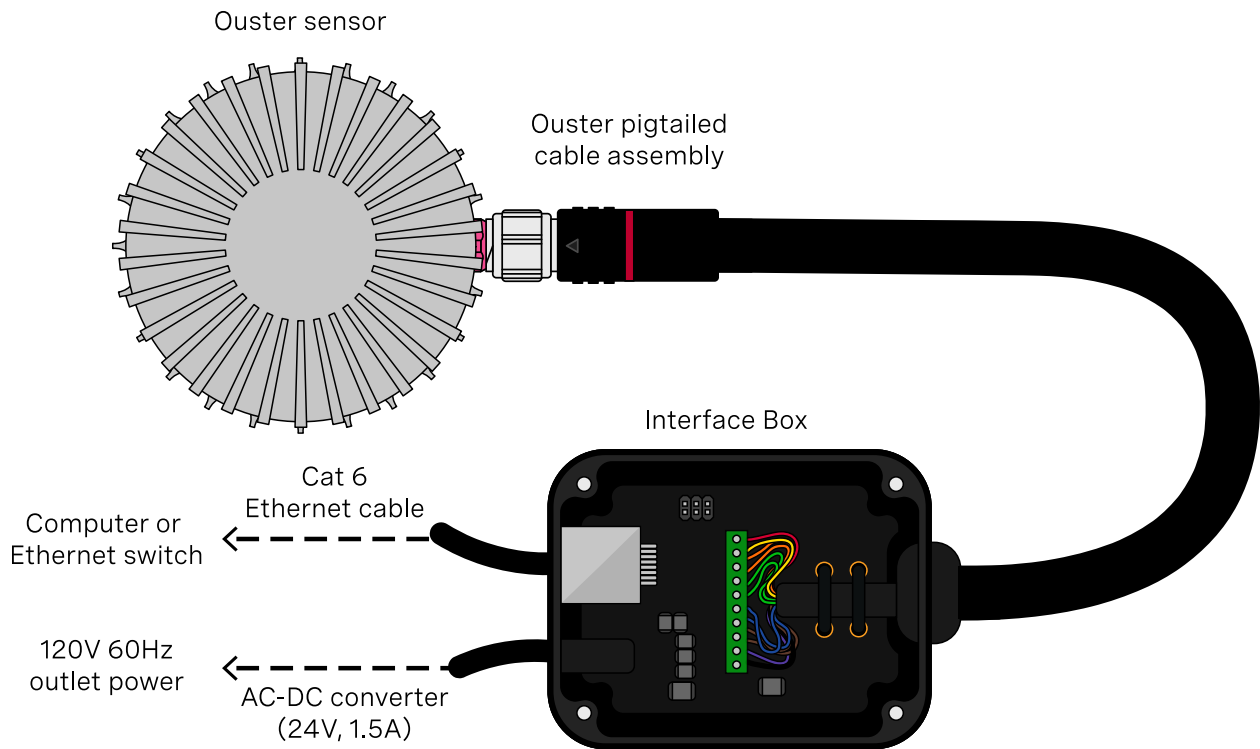

Cable Connection and Pinout

The OS1 can be operated without the use of an Interface Box. For more information on the Ouster Cable Pinout please refer to [Direct Cable Connection and Pinout](#)

7.2.2 Interface Box 12V (Compatible)

This type of interface box is engineered for users who require the use of 12V DC power supply. These interface Boxes also have a new GPS input connector capable of accepting operating TTL levels that originate in a separate GPS device containing a static electric dissipation circuit.

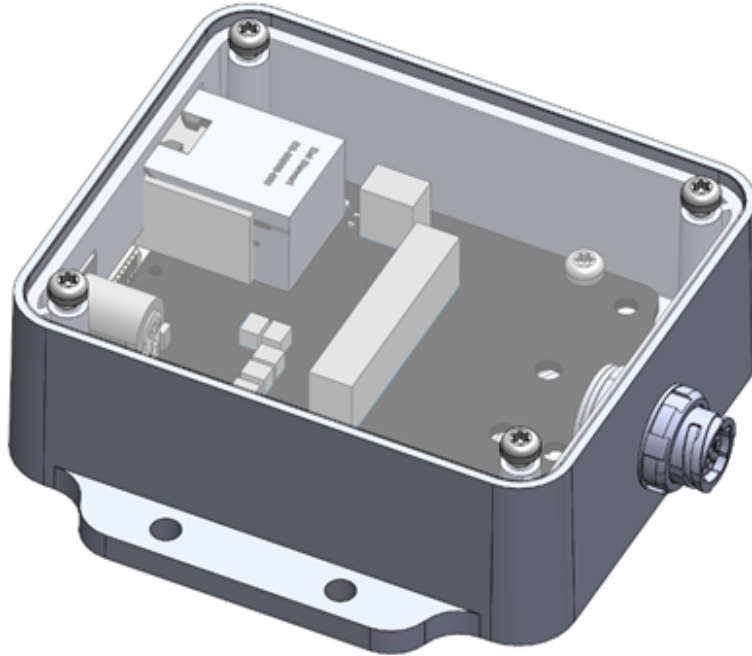

Figure 7.1: Interface Box -12V compatibility

Interface Box Specification

- 1 - This feature is optional for Rev 06 Sensor and above and is compatible with Type 3 Cables only. Standard Interface box without this connector is also available and is provided with Type 1 and Type 2 cables for connection to Ouster's sensor.
- 2 - Ethernet jack. RJ45, gigabit speed (1000base-T).
- 3 - VIN Barrel Jack. Use with a 2.5mm inner diameter, 5.5mm outer diameter barrel plug.
- 4 - User replaceable 5A fuse. Use only Littlefuse #0891005.
- 5 - VIN green LED indicator (D2), fuse-protected VIN header (J10) and Ground header / jumper storage (J14).
- 6 - Onboard MAXM15067 buck powering VCC_3P3|5. VCC_3P3|5 supplies the onboard LEDs and pullups, and is user accessible via headers J2 & J7. Header J5 is used to select the buck's output voltage: install a jumper for 3.3V, leave open for 5V. WARNINGS: Max allowable user consumption is 210mA. Ensure power to the Interface Box is disconnected when changing buck output voltage via J5.

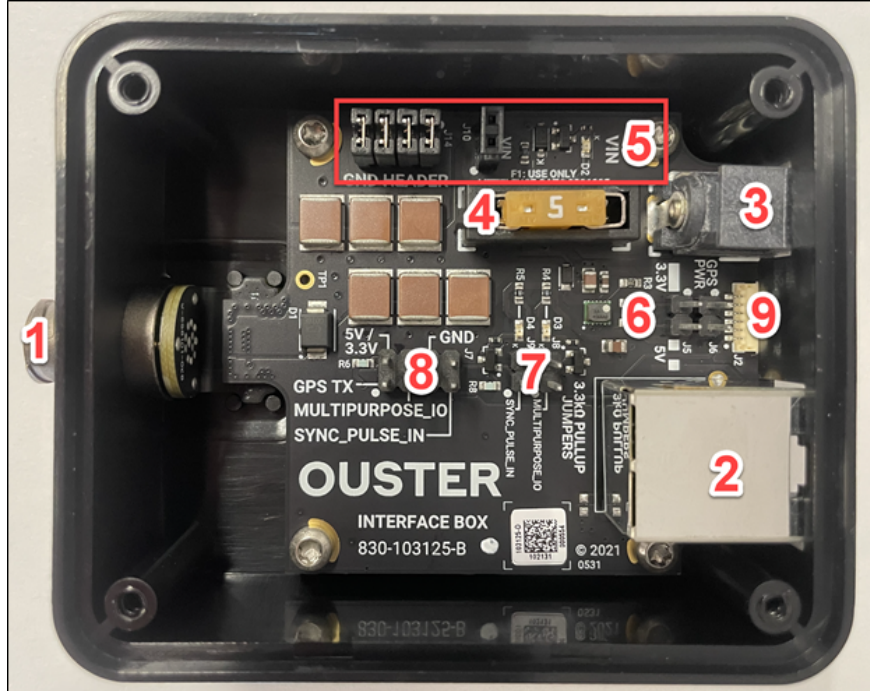

Figure 7.2: Components

- 7 - 3.3k Ω pullups to VCC_3P3|5 and green LED indicators for MULTIPURPOSE_IO and SYNC_PULSE_IN. Install a jumper on the respective header (J8 or J9) to enable the pullup.

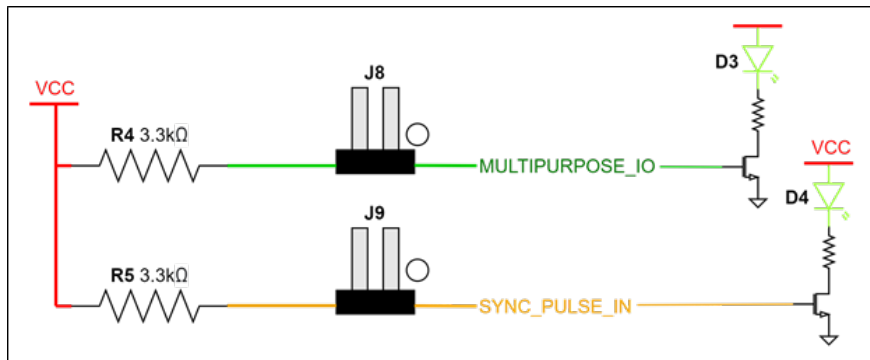

Figure 7.3: J8 & J9 Circuitry

- 8 - 0.1" pitch, 4x2 pin header J7. GPS_TX (Pin 1) is only connected to connector J2; it is not connected to the sensor.
- 9 - 6-pin JST SH/SR connector J2. VCC_J2 (Pin 2) is connected to VCC_3P3|5 by installing a jumper on header J6. GPS_TX (Pin 6) is only connected to header J7; it is not connected to the sensor.

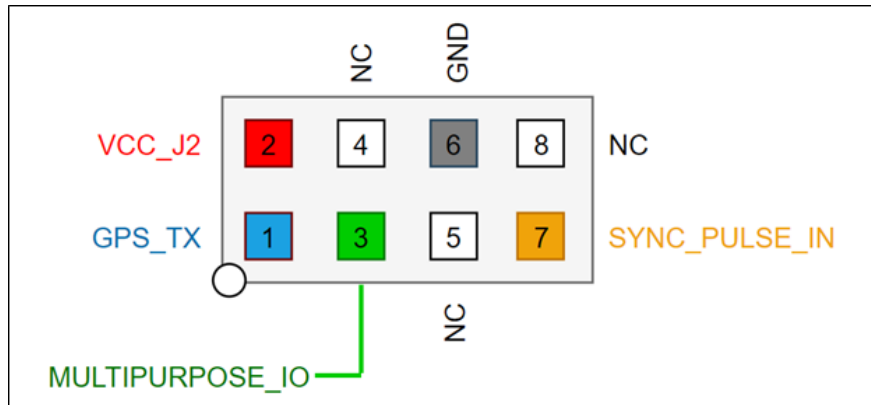

Figure 7.4: J7 Circuitry

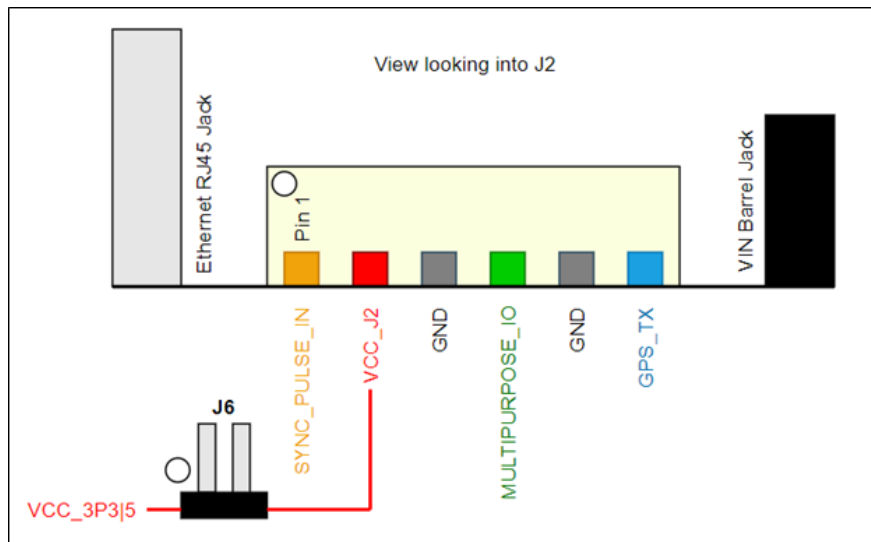

Figure 7.5: J2 Circuitry

Connectors

Connectivity Guide:

- RJ45: Ethernet connection to a computer
- 6-PIN JST SH/SR: GPS connector port
- Barrel Jack: 24V DC power supply

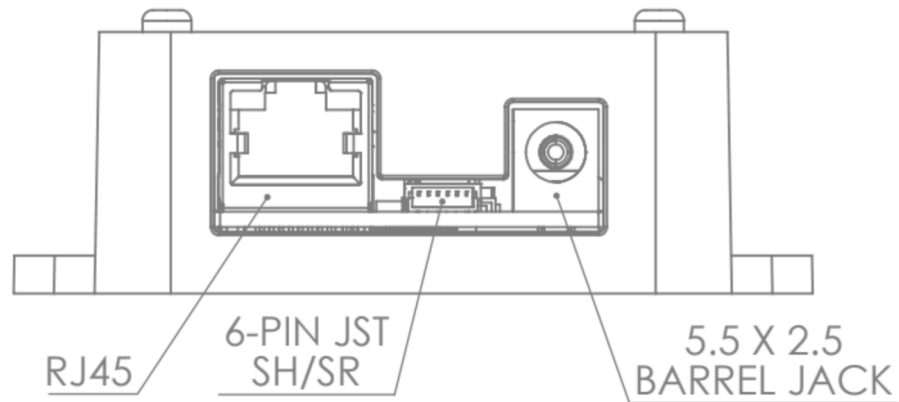

Figure 7.6: Connector Outline

Electrical Characteristics

The Type 1 and Type 2 cable Interface Boxes are rated 24 Vdc, 1.1 A and supports all Ouster sensors.

The Type 3 cable Interface Box is rated 12 Vdc, 3.3 A and 24 Vdc, 1.1 A. This Interface Box supports 24V operation on all Ouster sensors, and 12V operation for Rev 05 and above sensors only.

Overcurrent Protection

Type 1 and Type 2 cable Interface Boxes Interface Boxes are provided with thermistor type overcurrent protection to supplement the internal overcurrent protection in the sensor. The thermistor is soldered in place and is not user replaceable.

The Type 3 Interface Box contains a user replaceable 5A mini blade fuse. When replacing this fuse, use only a Littelfuse - Type 891005 fuse. Use of any other fuse may lead to a risk of fire.

Power Supply

The Interface Box ships with a 24 Vdc power supply and a cordset suitable for use in the U.S and Canada. Type 1 and Type 2 Interface Boxes are only designed for use with this 24 Vdc power supply and the Type 3 Interface Boxes are designed to operate from a 12 Vdc source, but a 12 Vdc power supply is not provided by Ouster.

To select a power supply, it should:

- Have a 12 Vdc output voltage rating.
- Be capable of delivering at least 3.3A.
- Be identified or marked as having a Limited Power Source (LPS) output.
- Be safety certified by an acceptable test house in the local region of use using either IEC 60950-1 or IEC 62368-1 (or the EN or other national equivalent).
- Be provided with a power supply cordset appropriate for the power supply's input and the socket outlets available in the lab space.
- Be provided with a 5.5 mm OD barrel type output connector suitable ID for a 2.5 mm OD inner pin.

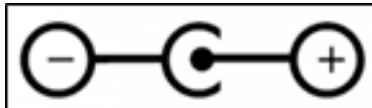

Selecting a Power Supply Cord/Cordset

If purchasing a power supply locally, it should be supplied with an appropriate power supply cord or cordset for use with the power supply. If it's necessary to select a power supply cordset for the Ouster supplied power supply, it should be safety certified by a test house acceptable to the local region of use, supplied with an IEC 60320, Type C6 cord connector to mate with the power supply and a plug for connection to an AC outlet with an earthing contact/pin.

Environmental Ratings

All Interface Boxes are suitable for use indoors only in clean, protected environments at temperatures between -20 °C and +50 °C. Interface Boxes are not designed for use outdoors or in environments that are not protected from dust, moisture, or high humidity.

Mounting

The interface box may be mounted on a table top or on a wall (or similar vertical surface) not higher than 2 m above the floor. Use not less than two (2) screws (M4 SHCS 10mm or longer are recommended) to secure the interface box to the mounting surface.

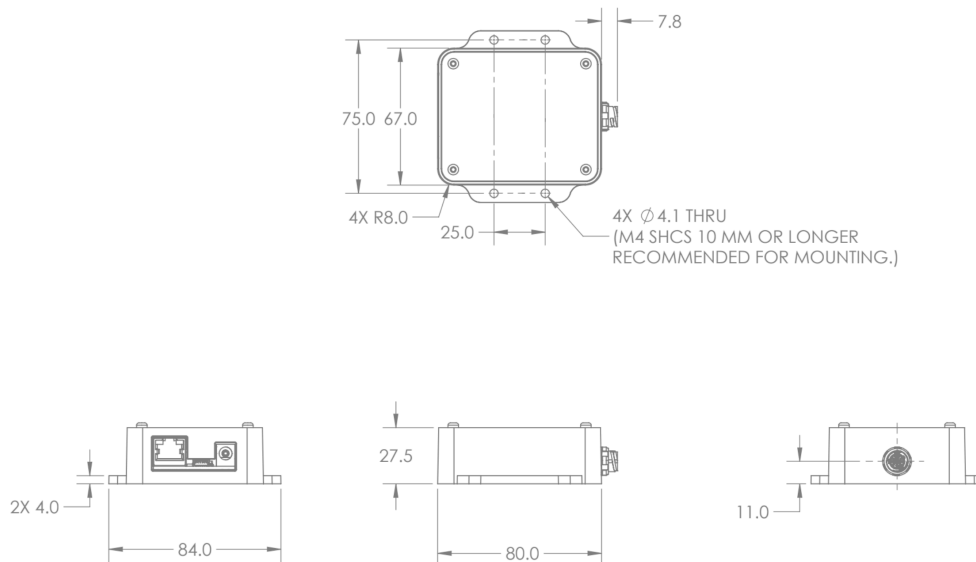

Figure 7.7: Mounting Guidelines - Ibox

For additional OS1 sensor CAD files refer to [Lidar Product Details](#) page.

8 GPS/GNSS Synchronization Guide

This guide will explain how to physically connect a GPS to your Ouster sensor and synchronize the Ouster sensor timestamp to an NMEA sentence.

8.1 Setting up your GPS/GNSS

It is important to ensure you have configured your GPS according to the manufacturer's specifications.

The Ouster sensor accepts the following:

- NMEA sentence type: **GPRMC** only (future support for other sentence types)
- Baud Rates: **9600** or **115200**
- Polarity: Normal or Reversed (**ACTIVE_HIGH**¹ or **ACTIVE_LOW**²)
- Voltage: **3.3 - 15 V** logic with a minimum drive current of **5 mA**.
 - If your GPS can't meet these minimums you will need to buffer the voltage with an additional circuit. Details in the Digital IO section of the Ouster Hardware User Manual.

Note: Once you have configured your GPS, it is good practice to verify the signals using an oscilloscope. This will ensure you have the correct baud rate, polarity, voltage, and message type being output.

1 Low to high edge as critical timing event

2 High to low edge as critical timing event

8.2 Connecting the Hardware

The next step to successfully connecting your GPS is ensuring that you have connected the outputs from your GPS to the correct inputs of the sensor.

For lab applications where you will use the Interface Box, it is recommended to use terminated jumper wires like these to ensure a solid connection.

Connection using the GPS Port

- Connect the PPS output from your GPS to the sync_pulse_in pin of the GPS connector to be plugged on the Ouster Interface Box, pictured below in yellow.
- Connect the NMEA UART output from your GPS to the multipurpose_io pin of the GPS connector to be plugged on the Ouster Interface Box, pictured below in magenta.
- Connect the ground output from your GPS to the GND pin of the GPS connector to be plugged on the Ouster Interface Box, pictured below in gray.

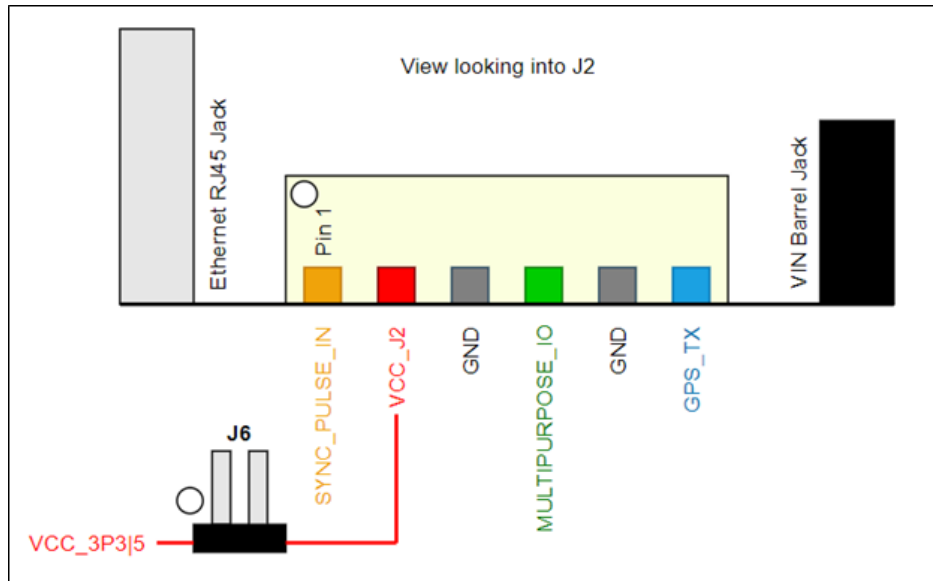

Figure 8.1: J2 Circuitry

Connection using the Pin out 4x2 pin header J7

- Connect the PPS output from your GPS to the sync_pulse_in pin of the Ouster Interface Box, pictured below in yellow.
- Connect the NMEA UART output from your GPS to the multipurpose_io pin of the Ouster Interface Box, pictured below in green.
- Connect the ground output from your GPS to the GND pin of the Ouster Interface Box, pictured below in gray.

Table 8.1: SYNC_PULSE_IN Interface Requirements

Parameter	Min Voltage	Max Voltage	Min Driver Current
LOGIC LOW	-30 V	2 V	N/A
LOGIC HIGH	2.9 V	30 V	3mA @3.3V~5V, 5mA at 24V and higher

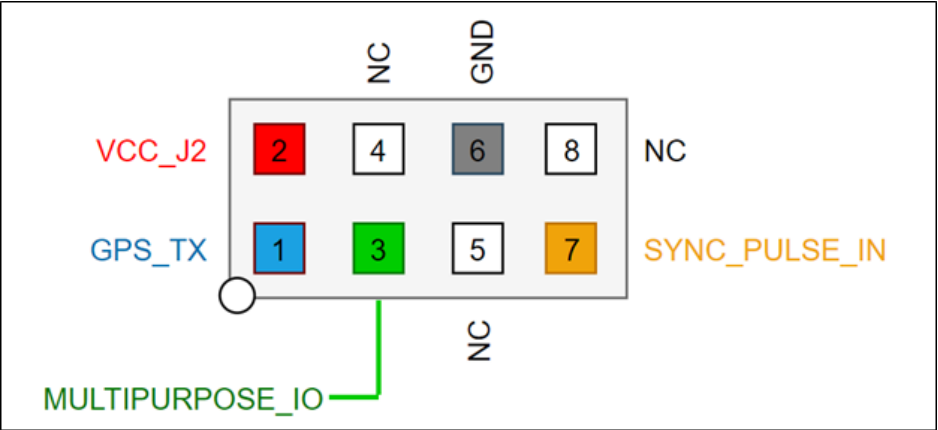

Figure 8.2: J7 Circuitry



Figure 8.3: Jumper Wires

Table 8.2: MULTIPURPOSE_IO - INPUT Interface Requirements

Parameter	Min Voltage	Max Voltage	Min Driver Current
LOGIC LOW	-30 V	2 V	N/A
LOGIC HIGH	2.9 V	30 V	3mA @3.3V~5V, 5mA at 24V and higher

8.3 Configuring the Ouster Sensor

Please refer to the GPS configuration section in the software user manual to configure your sensor to synchronize its timestamp with the GPS.

9 Support

In case of any questions regarding the contents of this user manual or the configuration of the sensor, please reach out to support@ouster.io or visit [Ouster website](#).