

INTREPID™

SOFTWARE DEVELOPMENT KITS (SDK)



Remote Polling Module II (RPM II)



INTREPID™ POE Communications

Southwest Microwave is committed to providing perimeter security solutions that will integrate seamlessly into our customers' overall security programs. We offer Software Development Kit (SDK) documentation to developers and systems integrators for INTREPID™ Series II perimeter intrusion detection systems (MicroPoint™ II, MicroTrack™ II, MicroWave 330) and INTREPID™ POE perimeter intrusion detection systems (Model 316-POE, Model 334-POE-S, Model 336-POE, MicroPoint-POE-S) enabling discovery, monitoring, command and control of these technologies through new or existing Physical Security Information Management (PSIM) or Video Management System (VMS) platforms and other custom control applications.

Southwest Microwave's SDK toolkits achieve a range of control and monitoring functionality* for the INTREPID™ Series II and POE sensor families and auxiliary inputs, including:

- Real-time notification of intrusion attempts, tamper and service alarms
- Monitoring of auxiliary inputs on all INTREPID™ devices for alarm and tamper conditions
- Tie-in of camera setting and position presets to fence, buried cable and microwave detection zones
- Visual assessment of intrusion attempts or tampering
- Storage of intrusion and tamper events in alarm history

With TCP/IP networks commonly used as a base for security and surveillance command and control applications, these SDK resources allow plug-and-play deployment of Southwest Microwave's INTREPID™ perimeter security solutions into today's network infrastructure.

* Scope of functionality is developer-dependent.

FLEXIBLE SDK OPTIONS

Our SDK toolkits facilitate the development of high-level interface between INTREPID™ Series II and POE perimeter intrusion detection solutions and third-party PSIM / VMS platforms or other custom control applications:



REMOTE POLLING MODULE II (RPM II) SDK

Part #5746792-A01

The Remote Polling Module II (RPM II) SDK is an application layer protocol / hardware combination that provides a method for third-party control or monitoring systems to interface with **INTREPID™ Series II sensors and auxiliary devices** through the INTREPID™ Remote Polling Module II (RPM II) via TCP/IP socket layer. This standard is specific to TCP/IP IPv4 socket communications.

With the RPM II SDK, only the INTREPID™ Remote Polling Module II (RPM II) is queried by the control or monitoring application. By eliminating the need for direct polling of each INTREPID device by the head-end system, the RPM II reduces time, cost and complexity associated with interface development.

Deployment of the RPM II SDK requires the purchase of an INTREPID™ Remote Polling Module II (RPM II) Controller, which handles polling of individual INTREPID™ Series II sensors and auxiliary devices.



REMOTE POLLING MODULE II (RPM II) SYSTEM CONTROLLER

The Remote Polling Module II (RPM II) is an INTREPID™ System Controller designed to provide network-based large or multi-site facilities with simplified high-level integration (via SDK) between third-party control or monitoring systems and INTREPID™ Series II sensors and auxiliary devices.

The RPM II is a self-contained hardware module with accompanying Software Development Kit (SDK) that eliminates the need for direct polling of each INTREPID™ device by the head-end system, dramatically simplifying interface development. The RPM II serves as Pollmaster — polling all INTREPID™ Series II sensors and auxiliary devices connected to its communications port for status, and communicating this information to the third-party control or monitoring system via TCP/IP network connection. The RPM II also provides secondary relay output interface with 128-zone capability.

RPM II KEY FEATURES

- PROVIDES INTERFACE VIA SDK TO INTREPID™ SERIES II SYSTEMS
- SECONDARY RELAY OUTPUT INTERFACE (128 ZONES)
- NETWORK-BASED LOCAL OR REMOTE ALARM REPORTING
- LOCAL OR REMOTE RPM II AND SENSOR CONFIGURATION / MAINTENANCE
- SINGLE OR MULTI-SITE MONITORING*
- CONNECTS UP TO 16 DEVICES
- INTUITIVE SETUP SOFTWARE

RPM II SPECIFICATIONS

Operating Temperature: -40° C to 70° C (-40° F to 158°F)

Size: 13.9 H x 33.7 W x 12.7 D cm (5.5 x 13.3 x 5 in)

Weight: 1.36 kg (3 lbs)

Input Power: 10.5 to 60 VDC

Current Draw: 12 VDC: 195 mA, 24 VDC: 100 mA, 48 VDC: 65 mA

Ports: RJ45 for network connection (1), USB-B (1), RS422 [2]

Languages: English

* For multi-site applications using the RPM II SDK, each site requires a unique RPM II Network System Controller.



INTREPID™ POE COMMUNICATIONS SDK

Part #5747169-A01 (SDK Document), Part #6447377-A01 (IPP_POE Services SDK Software Package),

Part #6447486-A01 (INTREPID POE-S Node Simulation Tool)

The INTREPID™ POE Communications SDK is an application layer protocol (IPP II) that enables third-party control or monitoring systems to query status and send commands between individual **INTREPID™ TCP/IP-based POE sensors and auxiliary devices**, which include:

- Model 316-POE-S Digital Microwave Link (316-POE-S)
- Model 334-POE-S Digital Microwave Link (334-POE-S)
- Relay Output Module-POE-S (ROM-POE-S)

- Model 336-POE-S Digital Microwave Link (336-POE-S)
- MicroPoint™ POE Processor Module-POE-S (PM-POE-S)
- Alarm Input Module-POE-8S (AIM-POE-8S)

The POE Communications protocol uses a packet/frame format to send/receive messages between a master and a slave. This standard is specific to TCP/IP communications.

With the POE Communications SDK, each INTREPID™ POE module is queried individually by the third-party control or monitoring application.

The POE Communications SDK is available in two formats: The SDK Customer Document (PDF file containing all necessary development instructions) or the IPP_POE Services SDK Software Package (containing API documentation, demos to discover, poll and notify alarm and status change of POE nodes, sample projects and SDK DLL libraries for third-party custom controller development.)

The INTREPID POE Node Simulation Tool is a software-based device emulator used to generate all available alarms from all POE-S devices for integration into a High-Level software platform. It is used in conjunction with the POE-S Communications SDK documentation.

RPM II INTEGRATION CONFIGURATION EXAMPLE

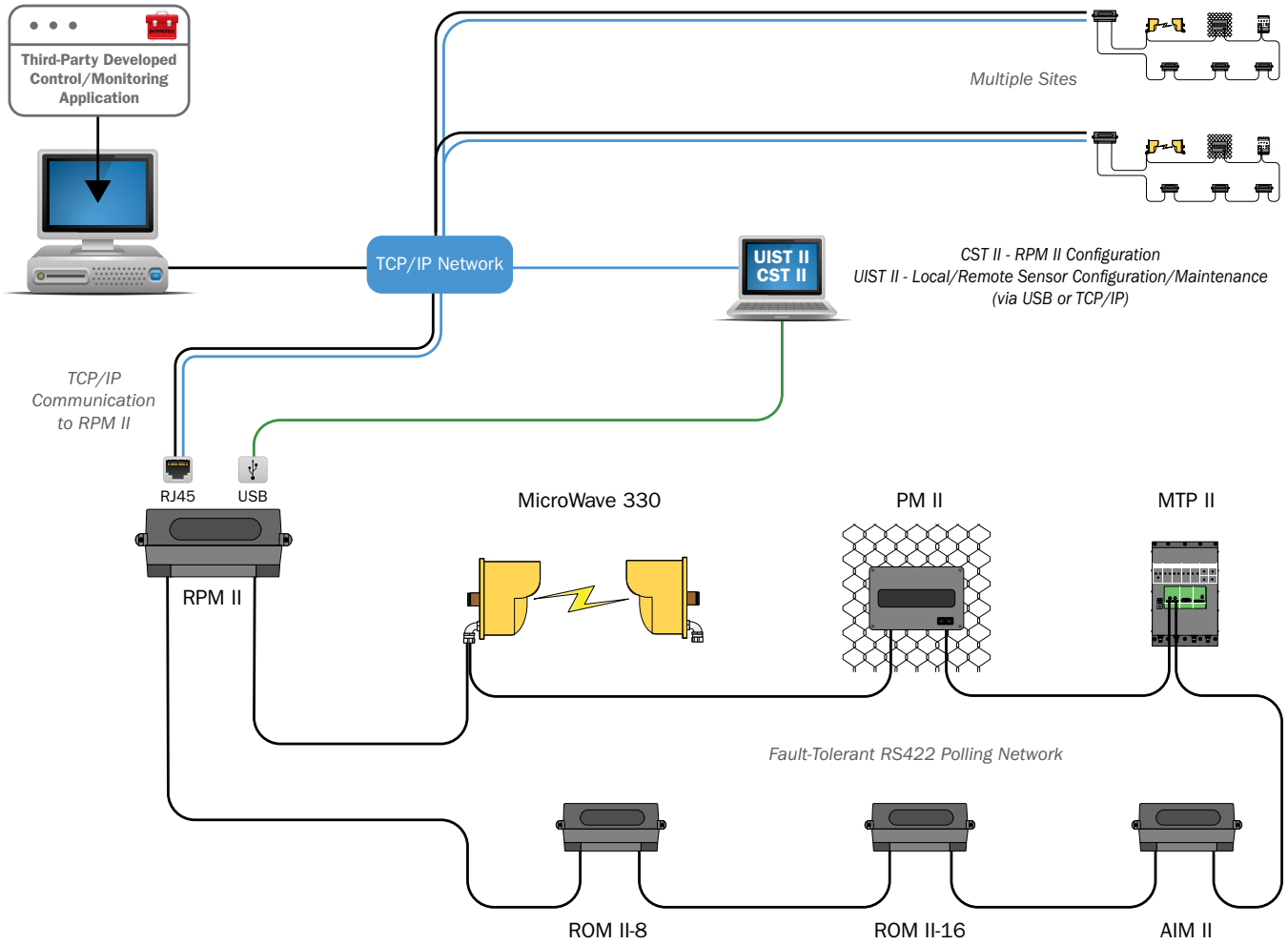

POE INTEGRATION CONFIGURATION EXAMPLE

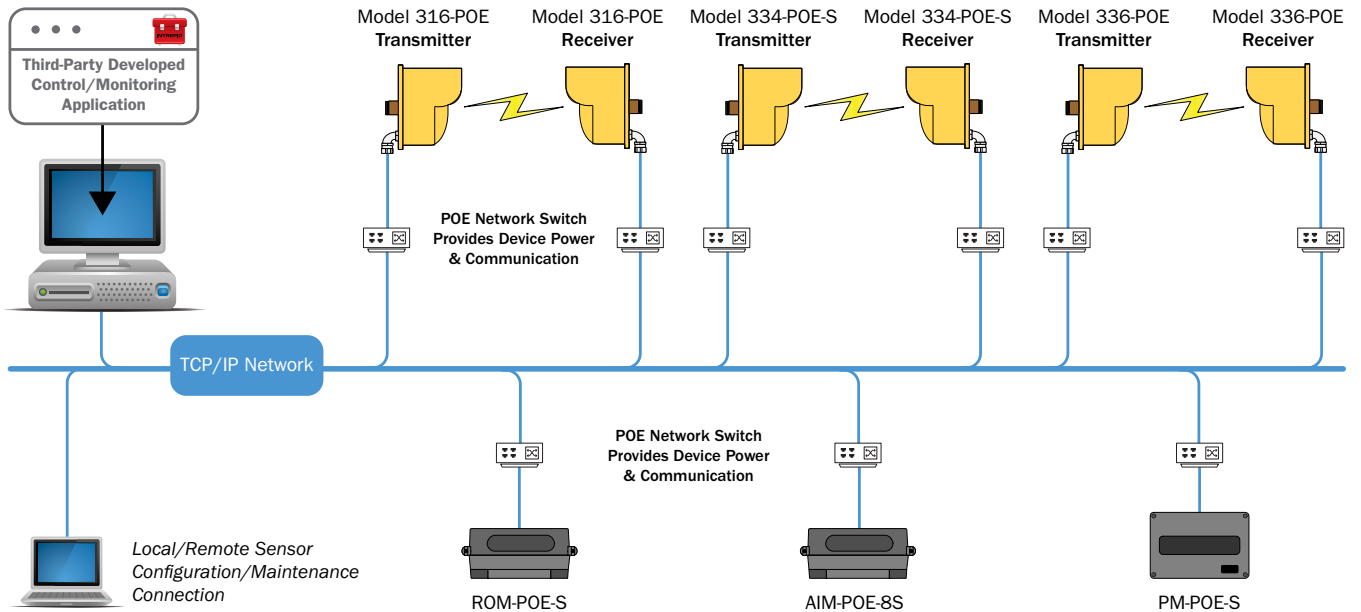

INTREPID™ SDK TECHNICAL QUICK REFERENCE

Southwest Microwave offers SDK options for integrating INTREPID™ Series II and POE devices with third-party PSIM and VMS platforms via TCP/IP network. These SDK packages enable extensive control and monitoring functionality for our INTREPID™ technologies. Use the following Technical Quick Reference to determine which protocol best suits your development needs:

INTREPID™ REMOTE POLLING MODULE II (RPM II)	INTREPID™ POE COMMUNICATIONS
<p>For integration with the following INTREPID™ Series II device types: MicroPoint™ Processor Module II (PM II), MicroNet™ Processor Module II (MPM II), MicroTrack™ Processor II (MTP II), MicroWave 330 Rx, Alarm Input Module II (AIM II), Relay Output Module II 8 (ROM II-8), Relay Output Module 16 (ROM II-16).</p>	<p>For integration with the following INTREPID™ POE device types: Model 316-POE (316-POE), Model 336-POE (336-POE), Model 334-POE-S (334-POE-S), MicroPoint™ POE Processor Module-POE-S (PM-POE-S), Relay Output Module-POE-S (ROM-POE-S), Alarm Input Module-POE-8S (AIM-POE-8S)</p>
<p>RPM II SDK Protocol / Hardware Combination</p> <ul style="list-style-type: none"> Requires INTREPID™ Remote Polling Module II (RPM II) controller (gateway for communication to INTREPID™ Series II* devices). Enables local or remote INTREPID™ device configuration and maintenance via Universal Installation Service Tool II (UIST II). 	<p>INTREPID™ POE Communications SDK Protocol</p> <ul style="list-style-type: none"> No INTREPID™ polling hardware required.
<p>Single Point Polling Structure</p> <ul style="list-style-type: none"> Requires development of one (1) alarm polling routine between PSIM/VMS and RPM II controller. PSIM/VMS polls RPM II at set interval. Polling may be synchronous or asynchronous. RPM II polls and receives alarm information for connected INTREPID™ devices at fixed intervals of 125 ms. Polling routine is identical regardless of number/type of INTREPID™ devices connected to RPM II or number of RPM II controllers being polled. Two (2) polling ports are available. 	<p>Device Level Polling Structure</p> <ul style="list-style-type: none"> Requires development of a unique alarm polling routine for each INTREPID™ POE device type. A separate polling message is sent by PSIM/VMS to each INTREPID™ POE device. PSIM/VMS receives alarm information directly from each INTREPID™ POE device. Polling interval is determined by network speed. Two (2) polling ports are available.
<p>Site Size Limitations</p> <ul style="list-style-type: none"> Maximum of 16 devices per RPM II. Unlimited RPM IIs may be incorporated per site. Multiple sites may reside on common IP network. Alarm delivery time is unaffected by adding additional RPM II controllers. 	<p>Site Size Limitations</p> <ul style="list-style-type: none"> Unlimited. Multiple sites may reside on common IP network. Alarm delivery time is unaffected by adding additional devices
<p>Programming Structure</p> <ul style="list-style-type: none"> Basic socket programming. Standard is specific to TCP/IP IPv4 socket communications. 	<p>Programming Structure</p> <ul style="list-style-type: none"> Packet/frame format. Standard is specific to TCP/IP IPv4 socket communications.
<p>System Management Capabilities</p> <ul style="list-style-type: none"> <i>Supports Basic Authentication:</i> Password required on connection to RPM II. <i>Optional Encryption:</i> Encrypted ethernet tunnel / software is available. <i>Redundant System Communications:</i> Two independent PSIM/VMS stations can poll RPM II simultaneously. <i>Fault Tolerance:</i> Two communications ports on RPM II enable bi-directional polling of INTREPID™ devices by RPM II. <i>Secondary Relay Output Interface (128 Zones)</i> 	<p>System Management Capabilities</p> <ul style="list-style-type: none"> <i>Supports Certificate Encryption:</i> Additionally, a password is required when connecting to INTREPID™ POE devices. <i>Redundant System Communications:</i> Based on network architecture. <i>Fault Tolerance:</i> Based on PSIM/VMS architecture.

Contact us at infosd@southwestmicrowave.com for further information or to request INTREPID™ SDK documentation.

* When selecting the INTREPID™ POE Communications protocol, the Developer is encouraged to include all INTREPID™ POE device types in the scope of interface development, since projects often contain multiple INTREPID™ POE device types, either from inception or during future expansion.

INTREPID™, MicroTrack™, MicroPoint™ and MicroNet™ are trademarks of Southwest Microwave, Inc.



USA (CORPORATE HEADQUARTERS): Southwest Microwave, Inc., Arizona, USA | Telephone +1 (480) 783-0201

EUROPEAN OFFICES: Southwest Microwave Ltd., Worcestershire, UK | Telephone +44 1386 75 15 11